



**Business Gateway
Developer pack**

Interface specification

Register Extract Service V2.1



Contents

1	Background	3
2	Purpose	3
3	Scope	3
4	Definitions, Acronyms and Abbreviations	3
5	Interface Specification	3
5.1	XML Requirements	3
6	Business Gateway	3
6.1	Business Gateway Process Diagram	4
6.2	Register Extract V2_1 Specific Messages	5
7	XML Schemas	5
7.1	Current list of XML Schemas	5
7.2	Schema Legend	6
Register Extract V2_0 Request		7
7.3	Request Message	7
7.4	Request Message Structure	7
7.5	Register Extract Request Specific Elements	8
7.6	TitleKnownOfficialCopy Elements	9
8	Register Extract Response	11
8.1	Response Message	11
8.2	Response Message Structure	11
8.3	Acknowledgement Response Structure	12
8.4	Rejection Response Structure	13
8.5	Result Response Structure	14
8.6	Common OCSummaryData Data Types	15
8.7	OCSummaryData Structure	21
8.8	OCRegisterData Structure	50
9	Glossary or terms and abbreviations	52
10	Annex A	52
10.1	RequestOCWithSummaryV2_0.xsd	53
10.2	ResponseOCWithSummaryV2_1.xsd	58



1 Background

This document provides the interface requirements for the Register Extract V2_1 Business Gateway service.

2 Purpose

The purpose of this document is to specify the interface between Land Registry and a Business Gateway Customer, indicating the message layouts and XML schemas that must be adhered to in order to communicate with LR, so that data may be exchanged between the organisations to effect Business Gateway.

The XML schemas associated with this interface represent the authoritative definition of the interface and takes precedence over any information in this document. The schemas will be issued with this document, along with sample requests.

3 Scope

The scope of this document encompasses the Register Extract V2_1 interface and XML message format.

4 Definitions, Acronyms and Abbreviations

Any specific terms and abbreviations are further explained in the Glossary.

5 Interface Specification

This section covers general information about the configuration and use of the interface.

XML Requirements

The XML schema attached as part of this document is compliant with 'XML Schema W3C Recommendation', 04 Feb 2004 and e-GIF standards. The XML version is 2.0 and encoding is UTF-8.

In an XML message, use of the characters &, <, " and ' is constrained. The characters & and < are permitted to represent themselves only in Comments, Processing Instructions and CDATA sections. The characters " and ' cannot appear in an attribute if they are being used to demarcate the value.

Escape sequences are used to represent these characters when required. These escape sequences are:

<u>Character</u>	<u>Escape Sequence</u>
&	&
<	<
>	>
"	"
'	'

Within CDATA blocks the above characters are permitted and escape sequences must not be used. CDATA blocks are used for attachments to messages.

6 Business Gateway



Business Gateway Process

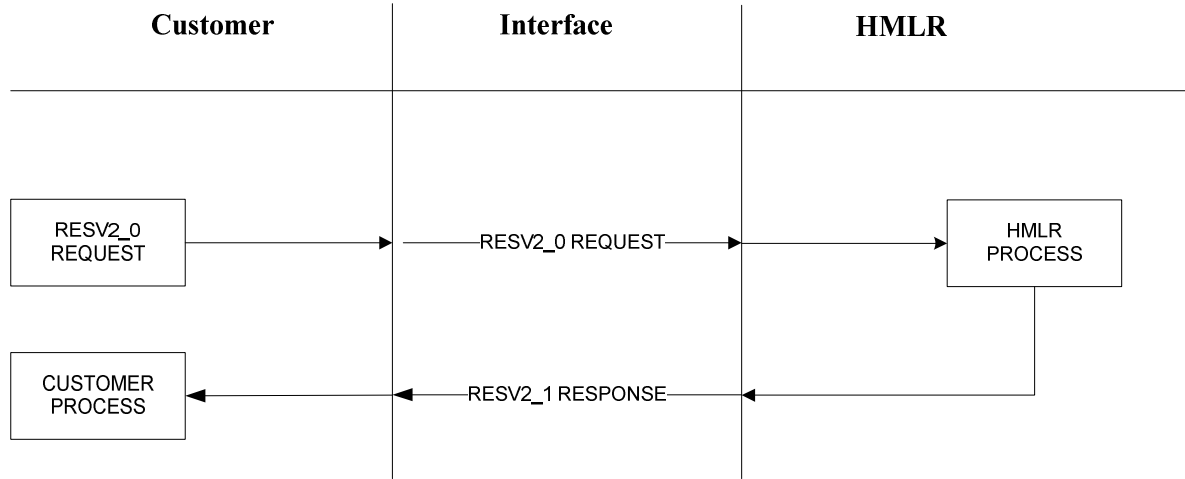

When using the Register Extract V2_1 service a Register Extract V2_0 Request and the Poll Request are acknowledged with a Register Extract V2_1 Response message.



Register Extract V2_1 Specific Messages

Schema : RequestOCWithSummaryV2_0

ResponseOCWithSummaryV2_1

Description : Register Extract requests allow a single title number to be supplied for a copy of the Official Copy Register in PDF format, an Official Copy of the Title Plan (if requested), the Register in XML format and a summary of the register also in XML format. The response indicates either:

- A success response with the PDF and XML version of the register as well as an Official Copy of the Title Plan, if requested, and the Official Copy Summary details.
- A System error
- Rejection with details of which documents are not available electronically.

7 XML Schemas

Current list of XML Schemas

Name	Version
RequestOCWithSummaryV2_0	1.0
ResponseOCWithSummaryV2_1	1.0
PollRequest	1.0

See Annexes for details of the individual Schemas relating to the Register Extract service.



Schema Legend

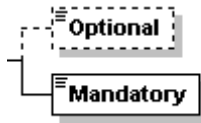

Optional data items appear as dotted boxes while lined boxes are mandatory items.

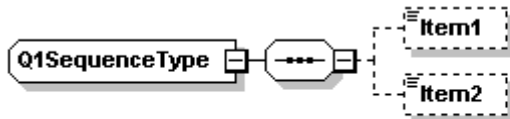

Sequences are identified by an elongated hexagon with three dots with a line running through it. The items that appear after the sequence are returned in that order.

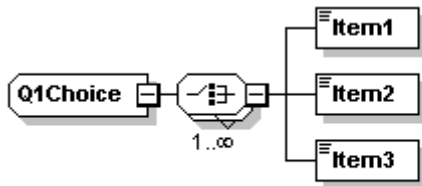

Choices are identified by an elongated hexagon with three dots ordered vertically with a line branching off each of the dots joining onto a single line. The items that appear after it can be returned in any order.



Request Message

The Register Extract V2_0 Request message uses the namespace http://www.oscre.org/ns/eReg-Final/2011/RequestOCWithSummaryV2_0 and must be valid with respect to the XML Schema published by the Land Registry for that namespace.

Message	Description
RequestOCWithSummaryV2_0	This message allows Customers to submit Register Extract Requests to LR.

1.

Request Message Structure

The request message comprises generic header information which is common with requests for other services, plus information specific to the OCWithSummaryV2_0 request. This is illustrated below:

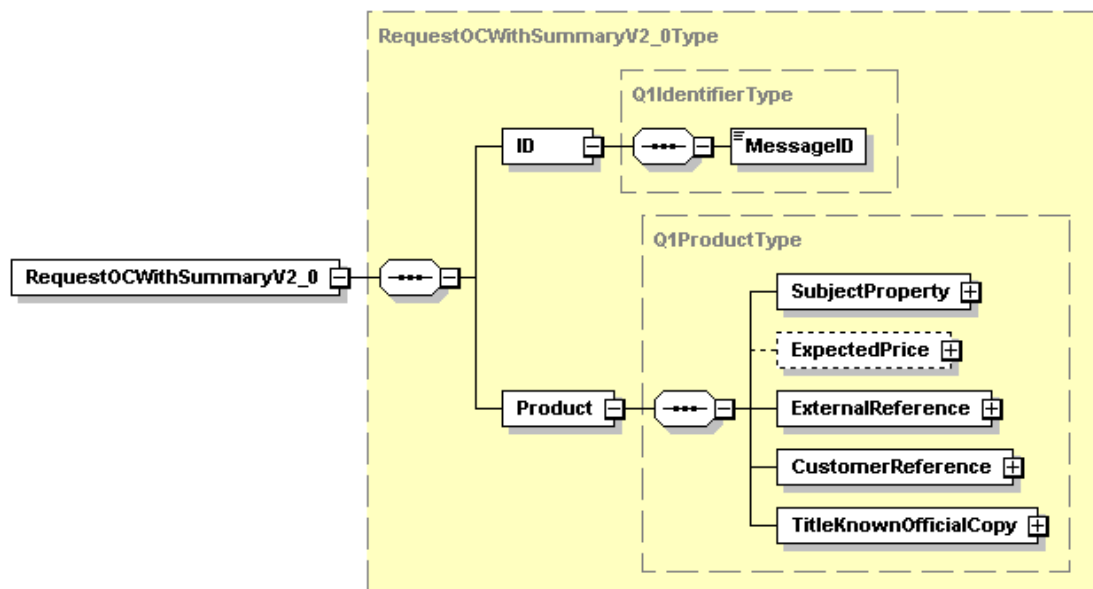

2.

3.

7.1.1 Key specific elements

Element	Description	Rules for Use
MessageID	Unique string of characters to identify the request message	Mandatory



Register Extract Request Specific Elements

The request message breakdown is illustrated below:

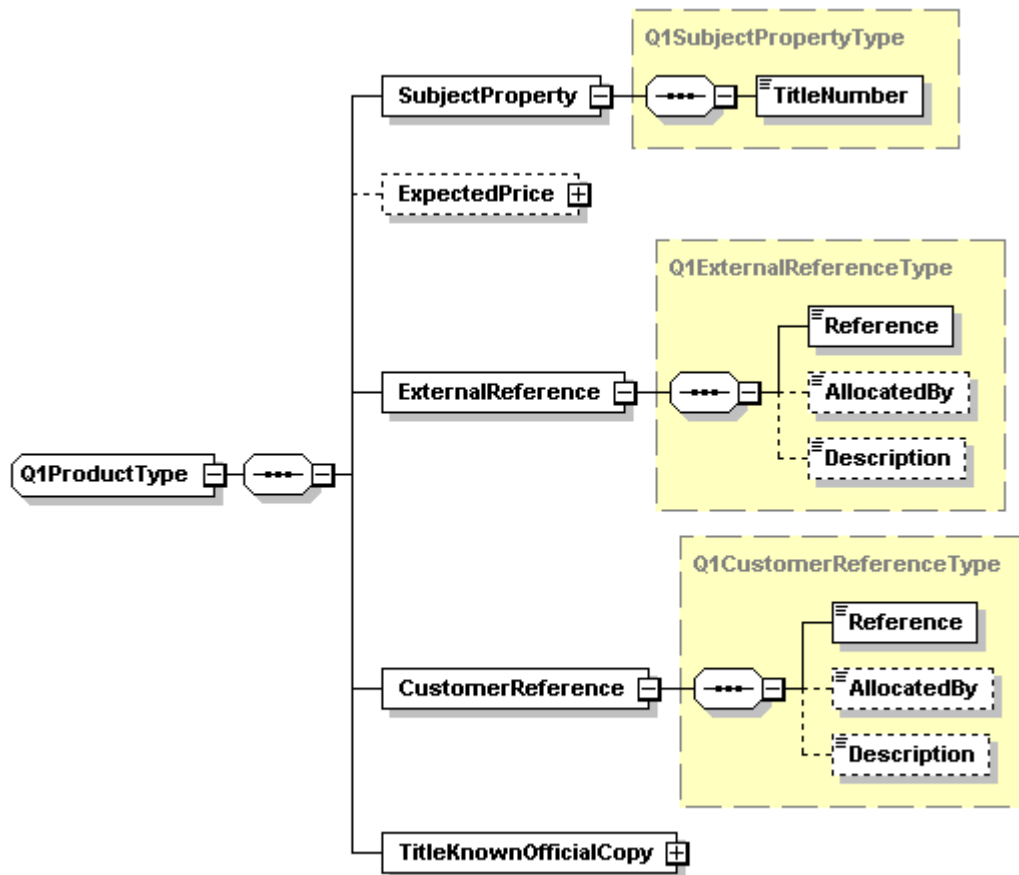

7.1.2 Key specific elements

Element	Description	Rules for Use
TitleNumber	The property title which is the subject of the transaction, or on which a search is being prepared	Mandatory
ExpectedPrice: GrossPriceAmount NetPriceAmount VATAmount	Information about price The gross price is the price including the VAT. The Net Price is the amount before the VAT. This is the amount of the VAT	Optional Optional Optional
ExternalReference: Reference AllocatedBy Description	Reference associated with a case in a Case Management System (CMS) A unique reference given to identify a particular request in the system of the organisation allocating it. The name of the organisation that has allocated the Reference This field can be used to provide reference description	Mandatory Optional Optional



Element	Description	Rules for Use
CustomerReference: (see External reference)	Reference for the person submitting the request (see External reference)	Mandatory
TitleKnownOfficialCopy	The ability for the external system to submit a request for an official copy using the title number. See Q1TitleKnownOfficialCopyType for expanded details	Mandatory

TitleKnownOfficialCopy Elements

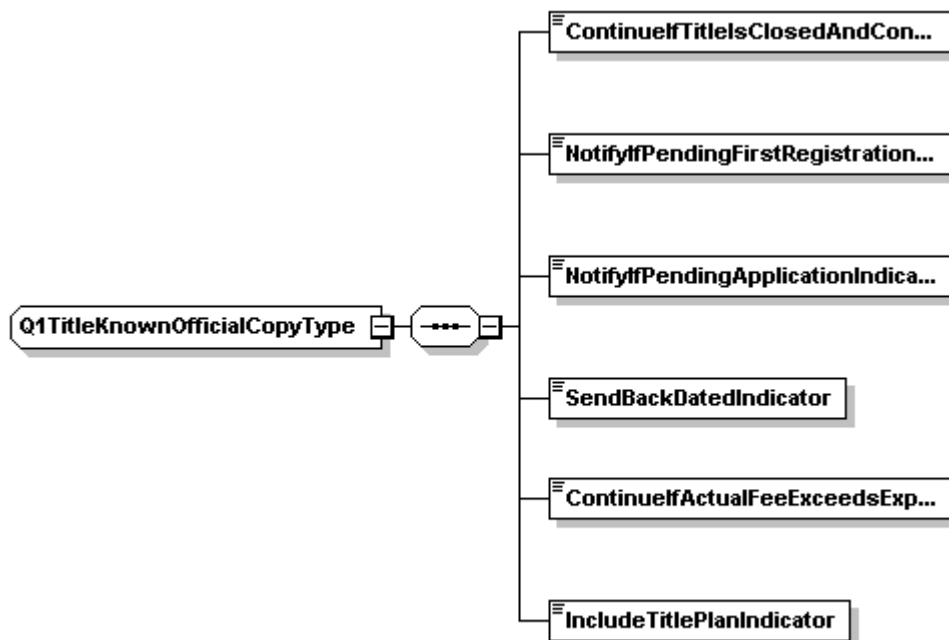

7.1.3 Key elements of the Q1TitleKnownOfficialCopyType element

HM Land Registry

Interface Specification



Element	Description	Rules for Use
ContinueIfTitlesClosedAndContinuedIndicator	An indicator sent by the CMS to the BG to advise whether to continue with the new Title number without warning	Mandatory
NotifyIfPendingFirstRegistrationIndicator	An indicator sent by the CMS to the BG to advise whether to continue where there is a pending new title application	Mandatory
NotifyIfPendingApplicationIndicator	An indicator sent by the CMS to the BG to advise whether to continue where there is a pending application	Mandatory
SendBackDatedIndicator	An indicator sent by the CMS to the BG to advise whether to issue back dated official copies	Mandatory
ContinueIfActualFeeExceedsExpectedFeeIndicator	An indicator sent by the CMS to the BG to advise whether to continue where the fee calculated by BG is more than the fee expected to be paid by the customer	Mandatory
IncludeTitlePlanIndicator	Indicator to request an electronic title plan for the requested property	Mandatory



8 Register Extract Response

Response Message

Register Extract V2_1 Response messages use the namespace http://www.oscre.org/ns/eReg-Final/2011/ResponseOCWithSummaryV2_1 and must be valid with respect to the XML Schema published by the Land Registry for that namespace.

Message	Description
ResponseOCWithSummaryV2_1	This message allows Land Registry to send Register Extract V2_1 Responses to the Customer.

Response Message Structure

The response message comprises generic information common with responses to other services, plus information specific to the Register Extract V2_1 response. This is illustrated below:

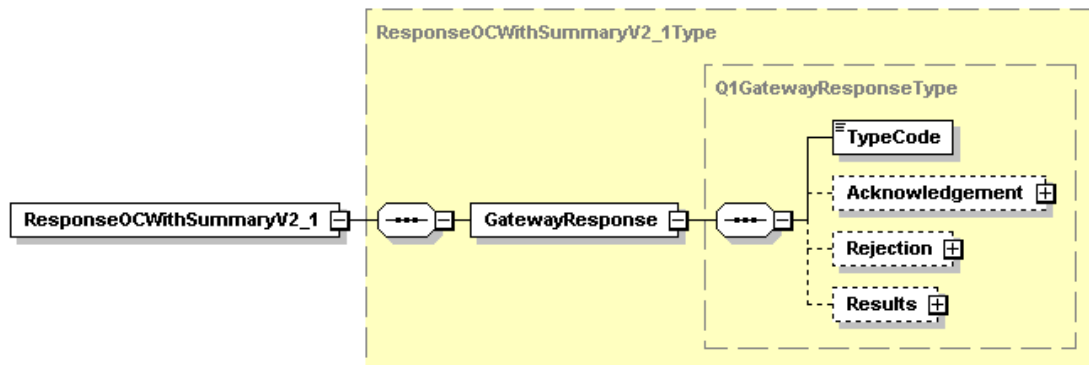

Element	Description	Rules for Use
TypeCode	Used to identify the response that will be issued to the CMS Vendor. Acknowledgement = 10 Rejection = 20 Result = 30	Mandatory
Acknowledgement	This is the Business Gateway confirmation response to the External System	Optional
Rejection	This is the Business Gateway rejection response to the External System	Optional
Results	This is the Business Gateway success response to the External System	Optional



Acknowledgement Response Structure

The purpose of the Acknowledgement message is to inform the originator of the Request message that it has been received and understood (positive acknowledgement).

If for any reason a valid acknowledgement is not received by the originator (i.e. through network error, corruption or incorrectly prepared XML) then there is no way for the server to know if it was successfully received or not. The Request or Response should be resent, at the risk of receiving a DUPLICATE acknowledgement.

The acknowledgement response structure is illustrated below:



8.1.1 Key specific elements

Element	Description	Rules for Use
UniqueID	A unique identifier used by the end user to get the status update of their request	Mandatory
ExpectedResponseDateTime	This element will hold the expected time when Business Gateway will try to process the queued request. This element will contain date and time data in a GMT format.	Mandatory
MessageDescription	This will be a String type element and will be used to display a message to the end user.	Mandatory



Rejection Response Structure

The purpose of the Rejection message is to inform the originator of the Request message that it has been rejected due to known circumstances.

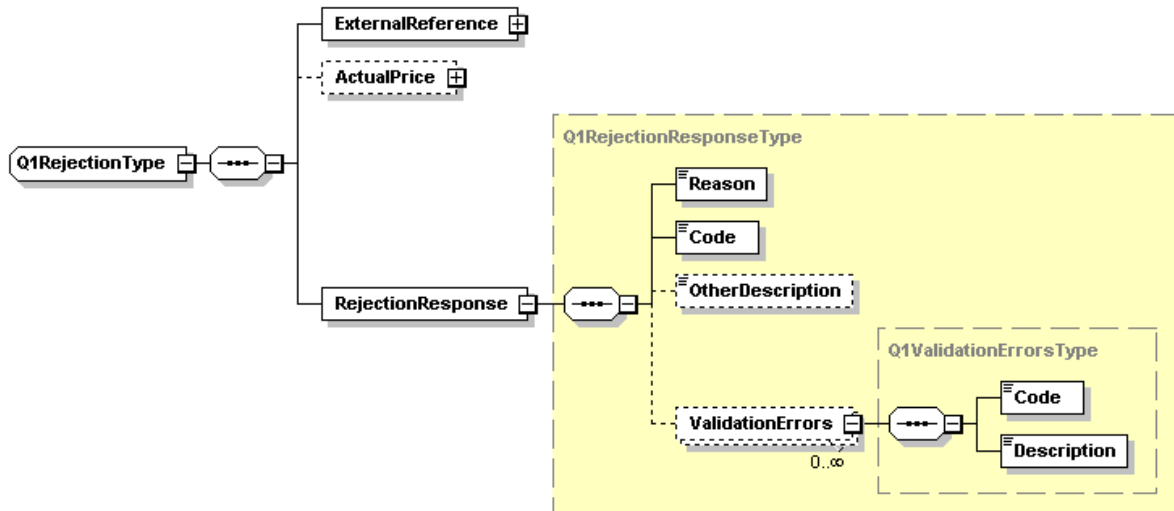

8.1.2 Key specific elements

Element	Description	Rules for Use
ExternalReference	A unique reference given to identify a particular request, order or instruction in the system of the organisation allocating it with the ability to associate the name of the Company that has allocated it.	Mandatory
ActualPrice	This is the actual fee payable for a Search/Product	Optional
Reason	<p>A description of the reason for rejection:</p> <ul style="list-style-type: none"> Your Official Copy request cannot be delivered electronically. Postal delivery is not available for the Register Extract Service. Your Official Copy Title Plan cannot be delivered electronically. Postal delivery is not available for the Register Extract Service. The Summary Data of your Official Copy Register cannot be delivered electronically. Postal delivery is not available for the Register Extract Service. <p>When the title plan is not available, it is still possible to order an Official Copy of the register to obtain the RES data.</p>	Mandatory
Code	A code signifying the reason for rejection	Mandatory
OtherDescription	A free format text field to convey any further information about the rejection.	Optional
ValidationErrors	Validation errors.	Optional
Description	A free format text field to convey any further information about the validation error.	Mandatory

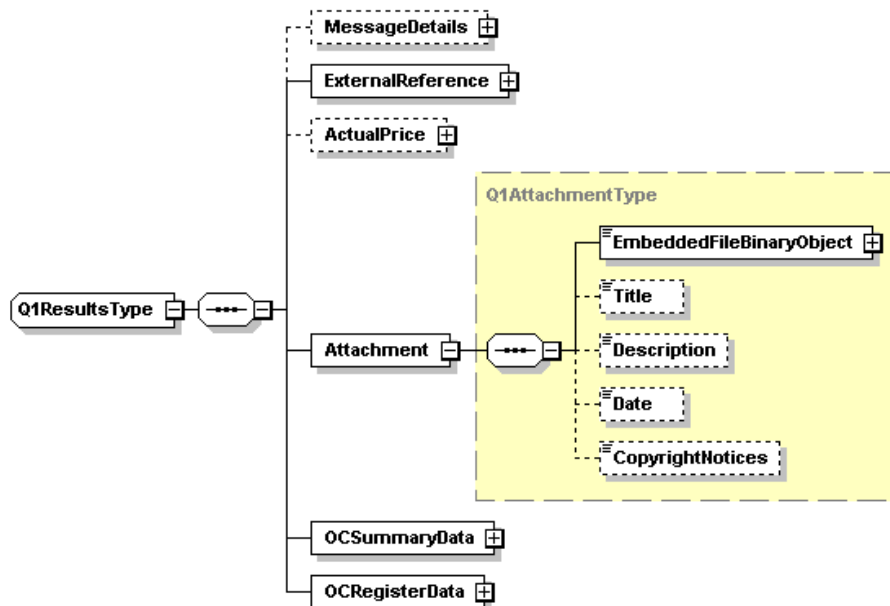

8.1.3 Key elements of the response

Element	Description	Rules for Use
MessageDetails	Optional description	Optional
ExternalReference	A unique reference given to identify a particular request, order or instruction in the system of the organisation allocating it with the ability to associate the name of the Company that has allocated it	Mandatory
ActualPrice	This is the price for a Search/Product	Optional
Attachment	An electronic copy of a document(s) that may be attached to a message in either PDF or ZIP format	Mandatory
OCSummaryData	Register extract information (see 9.6)	Mandatory
OCRegisterData	XML representation of the Official Copy of the register (see 9.7)	Mandatory



Common OCSummaryData Data Types

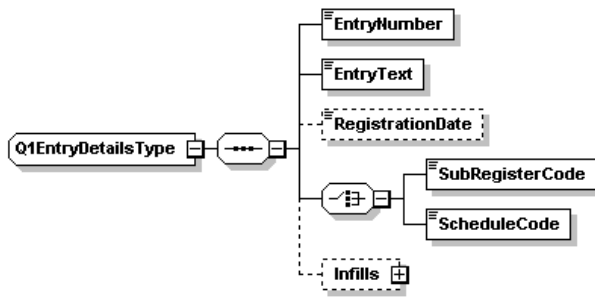

8.1.4 Key elements of the Q1EntryDetailsType

The Q1EntryDetailsType is a common data type used for most entries returned in the response schema. Entries will either be a Q1EntryDetailsType or of a specific entry type that contains a Q1EntryDetailsType. Q1EntryDetailsType consists of a sequence of elements that are either mandatory or optional as well as a choice of either a SubRegisterCode or ScheduleCode. The Infills element will consist of other data items that form the EntryText.

Element	Description	Rules for Use
EntryNumber	The entry number within the relevant Sub-Register or Schedule	Mandatory
EntryText	The text of a particular entry on the register	Mandatory
RegistrationDate	Date that the entry was registered	Optional
ScheduleCode	The Type of schedule the entry refers to. 10 - Schedule of Leases of Easements 20 - Schedule of Single Registered Lease 30 - Schedule of Notice of Leases 40 - Schedule of Registered Properties 50 - Schedule of Registered Rentcharges 60 - Schedule of Restrictive Covenants 70 - Schedule of Apportioned Rents 80 - Schedule of Rentcharges 90 - Schedule of Apportionments and Exonerations 100 - Schedule of Rentcharges created by Transfers of Part 110 - Schedule of Personal Covenants 120 - Schedule of Single Registered Rentcharge Lease 130 - Schedule of Multiple Registered Leases 140 - Schedule of Deeds imposing Restrictive Covenants	Optional
SubRegisterCode	Code which identifies an entry to a subset of the register of title. A - Property Register B - Proprietorship Register C - Charges Register D - Cautioner's Register	Optional



Element	Description	Rules for Use
Infills	Contains the infill data elements that constitute an Entry text. Explained in detail in the Q1InfillDetailsType definition.	Optional

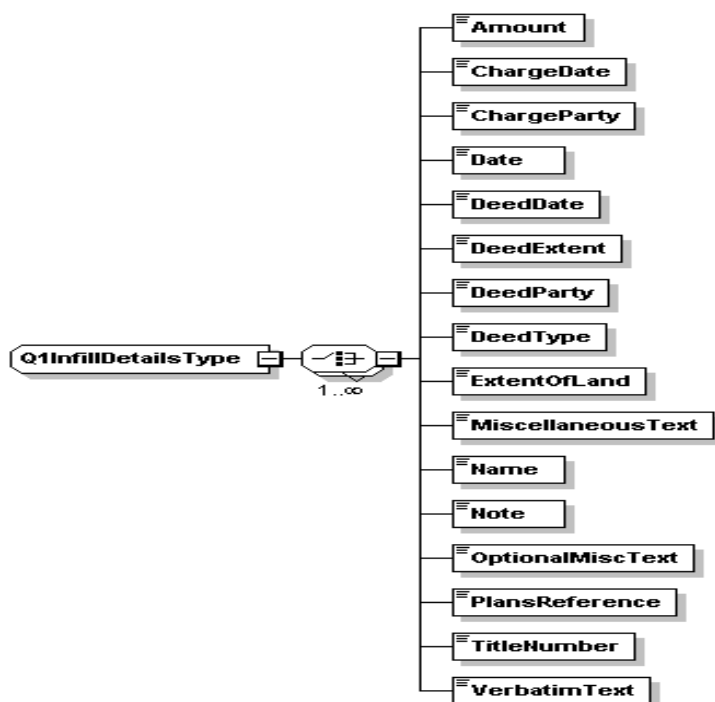

8.1.5 Key elements of the Q1InfillDetailsType

The Q1InfillDetailsType is an optional element found in the Q1EntryDetailsType. This element contains data items (infills) that form part of the Q1EntryDetailsType EntryText element. The Q1InfillDetailsType is an unbounded list that can consist of any of the data items in any order but will always be returned in the order they appear on the Entry Text. Although design shows all the items as mandatory, not all items are required to be returned. This design just enforces that one of the data items must exist if a Q1InfillDetailType exists.

Element	Description	Rules for Use
Amount	Value denoting a monetary value	Optional
ChargeDate	The date of the charge	Optional
ChargeParty	Name of the chargee	Optional
Date	Date infill for the entry text	Optional
DeedDate	Date on which the deed was drawn up	Optional
DeedExtent	Text which describes the extent of land affected by a deed	Optional
DeedParty	Names of those associated with a deed	Optional
DeedType	The type of Deed.	Optional
ExtentOfLand	Text which describes the extent of land	Optional
MiscellaneousText	Text containing any additional information which forms part of an entry on the register	Optional

HM Land Registry

Interface Specification



Element	Description	Rules for Use
Name	Infill name	Optional
Note	Text contained in a note which forms part of an entry on the register	Optional
OptionalMiscText	Text containing any additional information which forms part of an entry on the register	Optional
PlansReference	Reference shown on an explanatory plan	Optional
TitleNumber	A unique identifier for a title	Optional
VerbatimText	Text containing any additional information which forms part of an entry on the register	Optional

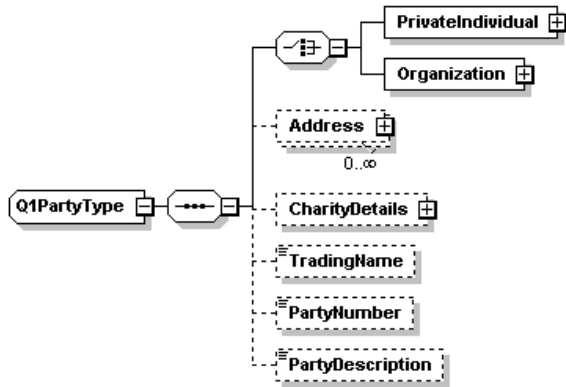

8.1.6 Key elements of the Q1PartyType

The Q1PartyType is a common element used to store details of a private individual or an organisation. This is modelled as a choice in the diagram where it is mandatory to have one or the other provided. Q1PartyType is used to record registered proprietor, cautioner, charge and lease party details.

Element	Description	Rules for Use
PrivateIndividual	See Q1PrivateIndividualType definition for an expanded description.	Optional
Organisation	See Q1OrganisationType definition for an expanded description.	Optional
CharityDetails	See Q1CharityDetailsType definition for an expanded description.	Optional
TradingName	A private individual or company that carries out business transactions under another name.	Optional
PartyNumber	Number denoting order of the party	Optional
PartyDescription	The description of the parties that make up a lease that are shown in the H schedule i.e. Lessee and Lessor	Optional

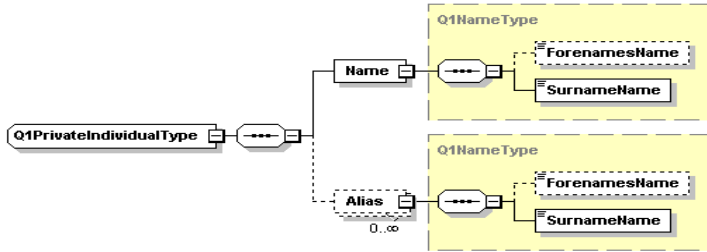

8.1.7 Key elements of the Q1PrivateIndividualType

The Q1PrivateIndividualType is a common element used to store details of individual persons not registered as a company.

Element	Description	Rules for Use
Name	Details of the private individual's name	Mandatory
Alias	Alternative name for the private individual	Optional
ForenamesName	Forename(s)	Optional
SurnameName	Surname	Mandatory

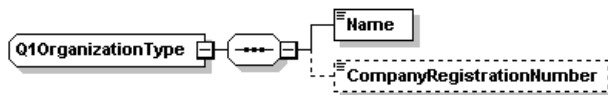

8.1.8 Key elements of the Q1OrganisationType

The Q1OrganisationType is a common element used to store details of a company.

Element	Description	Rules for Use
Name	Name of the Organisation	Mandatory
CompanyRegistrationNumber	Registration number for a company registered at Companies House and registered as the proprietor of the land or caution	Optional

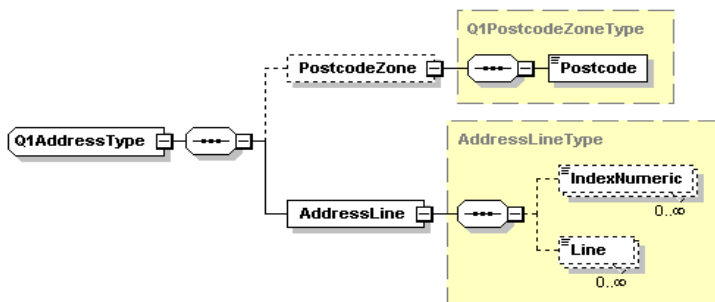

8.1.9 Key elements of the Q1AddressType

The Q1AddressType is a common element used to address details.



Element	Description	Rules for Use
PostcodeZone	Element that contains the postcode	Optional
Postcode	Post code for the property	Mandatory
AddressLine	Contains the address of the property broken down per line.	Mandatory
IndexNumeric	Number	Optional
Line	Details of address broken down per line	Optional

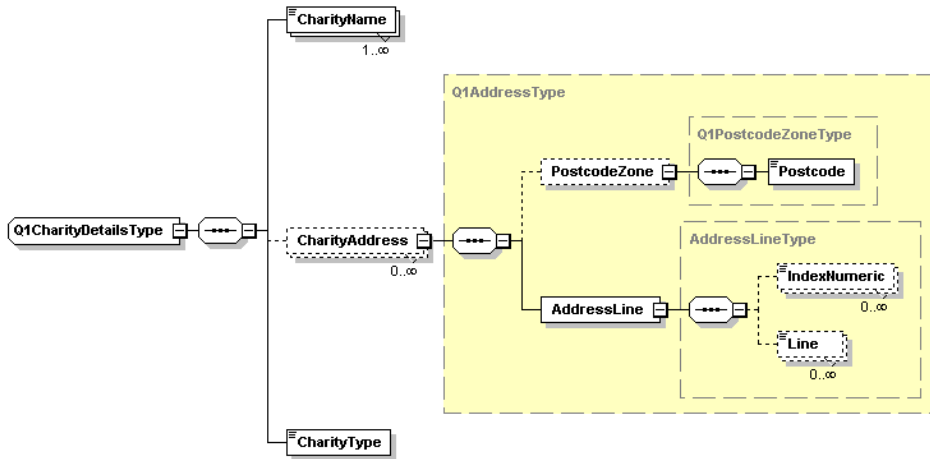

8.1.10 Key elements of the Q1CharityDetailsType

The Q1CharityDetailsType is a common element used to store charity details.

Element	Description	Rules for Use
CharityName	The name of a charity proprietor as proprietor of the estate or charge	Mandatory
CharityAddress	The address of a charity	Optional
CharityType	The type of charity proprietor. C - Charity R - Official Custodian for Charities S - Official Custodian for Charities (Trustees)	Mandatory



8.1.11 Key elements of the OCSummaryData

Element	Description	Rules for Use
OfficialCopyDateTime	Date and time of the associated official copy.	Mandatory
EditionDate	Date of the latest edition of the register	Mandatory

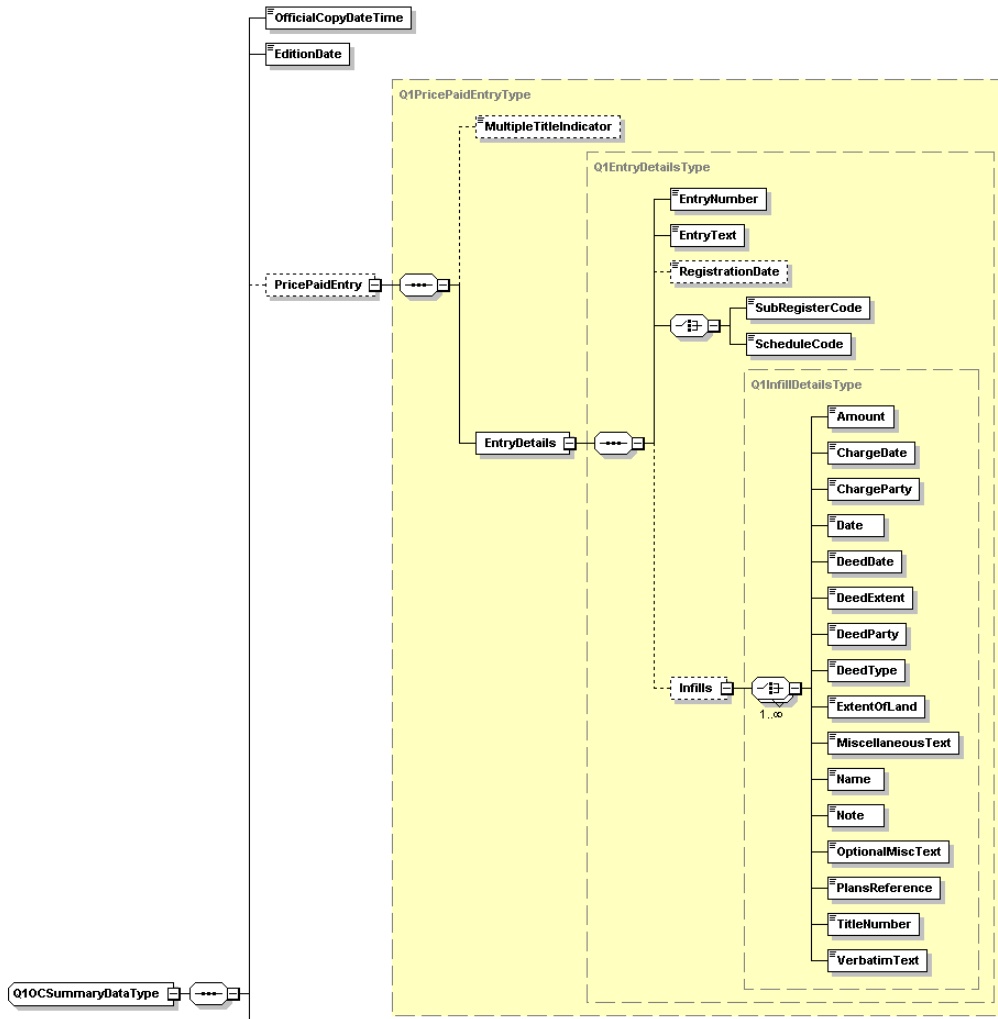

8.1.12 Key elements of the PricePaidEntryType

Element	Description	Rules for Use
MultipleTitleIndicator	Indicator showing whether an entry affects other titles	Optional
EntryDetails	See Q1EntryDetailsType definition for an expanded description. Types relevant to Q1PricePaidEntryType: EntryNumber EntryText RegistrationDate ScheduleCode SubRegisterCode	Mandatory Mandatory Optional Optional Optional
Infills	See Q1InfillDetailsType definition for expanded description. Types relevant to Q1PricePaidEntryType: Amount Date MiscellaneousText	Optional Optional Optional

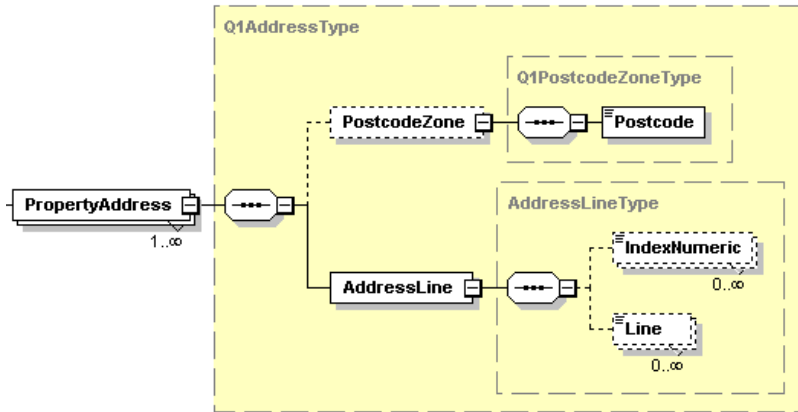

8.1.13 Key elements of the PropertyAddress element

Element	Description	Rules for Use
PropertyAddress	Address of the property associated with the title number	Mandatory
PostcodeZone	Element containing the postcode	Optional
AddressLine	Contains the property address	Mandatory

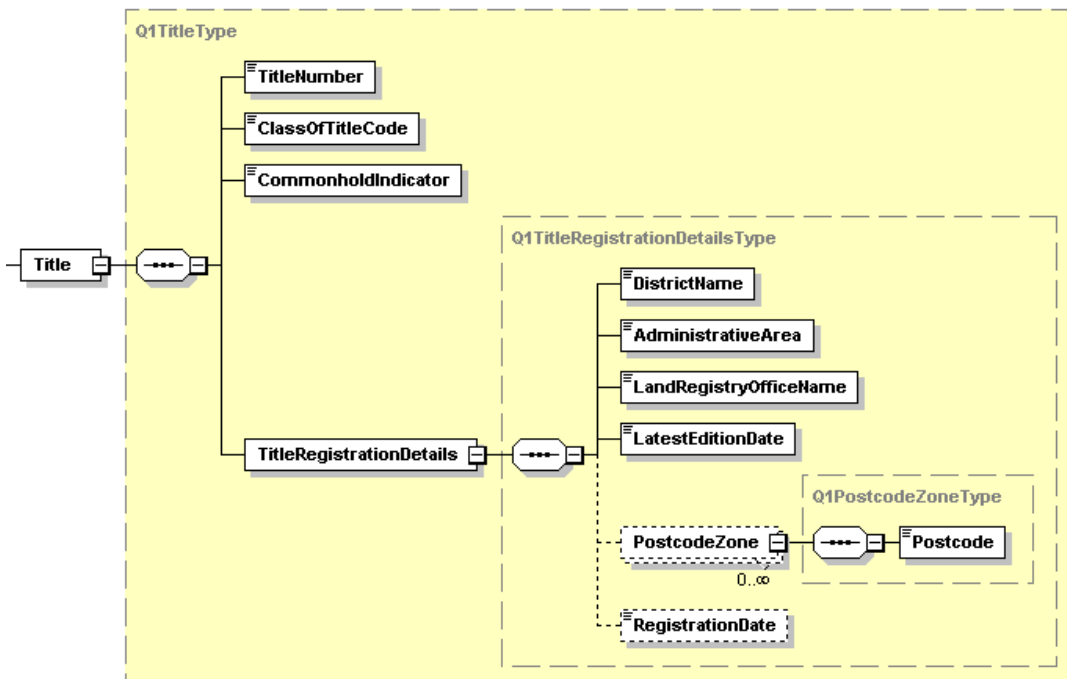

8.1.14 Key elements of the Title element



Element	Description	Rules for Use
TitleNumber	A unique reference number given to a piece of registered land	Mandatory
ClassOfTitleCode	The class of title is granted to the proprietor based on the proof provided that they are in rightful ownership. 10 – Absolute Freehold 20 - Possessory Freehold 30 - Qualified Freehold 40- Scheme Title - Freehold 50 - Scheme Title - Leasehold 60 - Absolute Leasehold 70 - Good Leasehold 80 - Qualified Leasehold 90 - Possessory Leasehold 100 - Absolute Rentcharge 110 - Possessory Rentcharge 120 - Qualified Rentcharge 130 - Caution Against First Registration	Mandatory
CommonholdIndicator	Indicator showing whether the title is commonhold property	Mandatory
DistrictName	Name of the district that the title belongs in. If the title falls under multiple districts only the first district will be revealed.	Mandatory
AdministrativeArea	Name of the administrative area that title belongs in.	Mandatory
LandRegistryOfficeName	Name of the Land Registry office to whom the title belongs.	Mandatory
LatestEditionDate	Date of latest edition	Mandatory
PostcodeZone	Element containing the postcode	Optional
RegistrationDate	Date that the entry was registered	Optional

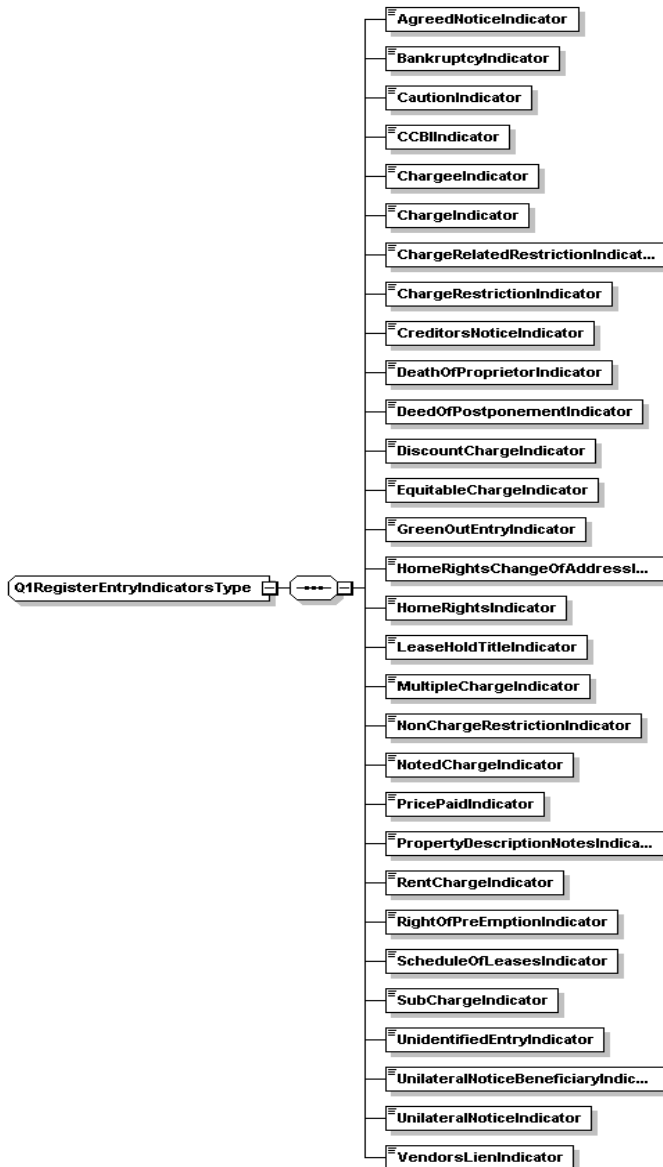

8.1.15 Key elements of the RegisterEntryIndicators element

This RegisterEntryIndicators will display what entry are present on the register. If an indicator is set to true, then a corresponding entry will be returned in the summary. The only exception to this rule is for ScheduleOfLeasesIndicator and PropertyDescriptionNotesIndicator, where no entry details will be returned.

Element	Description	Rules for Use
AgreedNoticeIndicator	Indicates the existence of an Agreed Notice in the charges register	Mandatory
BankruptcyIndicator	Indicates the existence of a bankruptcy entry in the register	Mandatory
CautionIndicator	Indicates the existence of a caution entry in the register	Mandatory
CCBIndicator	Indicates the existence of a Caution/Creditor Notice/Bankruptcy/Inhibition entry in the register	Mandatory
ChargeeIndicator	Indicates the existence of a Chargee entry in the register	Mandatory
ChargeIndicator	Indicates the existence of a Charge entry in the register	Mandatory
ChargeRelatedRestrictionIndicator	Indicates the existence of a Charge Related Restriction entry in the register	Mandatory



Element	Description	Rules for Use
ChargeRestrictionIndicator	Indicates the existence of a Charge Restriction entry in the register	Mandatory
CreditorNoticeIndicator	Indicates the existence of a Creditor Notice entry in the register	Mandatory
DeathOfProprietorIndicator	Indicates the existence of an entry relating to the death of a registered proprietor of the estate	Mandatory
DeedOfPostponementIndicator	Indicates the existence of a Deed of Postponement entry in the register	Mandatory
DiscountChargeIndicator	Indicates the existence of a Discount Charge entry in the register	Mandatory
EquitableChargeIndicator	Indicates the existence of a Equitable Charge entry in the register	Mandatory
GreenOutEntryIndicator	Indicates the existence of a Green Out entry in the register	Mandatory
HomeRightsChangeOfAddressIndicator	Indicates the existence of a Home Rights Change Of Address entry in the register	Mandatory
HomeRightsIndicator	Indicates the existence of a Home Rights entry in the register	Mandatory
LeaseHoldTitleIndicator	Indicator showing whether the Title is a Leasehold Class of Title	Mandatory
MultipleChargeIndicator	Indicator showing whether multiple charges exist	Mandatory
NonChargeRestrictionIndicator	Indicates the existence of a Non-Charge Restriction entry in the register	Mandatory
NotedChargeIndicator	Indicates the existence of a Noted Charge entry in the register	Mandatory
PricePaidIndicator	Indicates the existence of a Price Paid entry in the register	Mandatory
PropertyDescriptionNotesIndicator	Indicator showing whether any notes exist in association with the property description.	Mandatory
RentChargeIndicator	Indicates the existence of a Rent Charge entry in the register	Mandatory
RightOfPreEmptionIndicator	Indicates the existence of a Right Of Pre-emption entry in the register	Mandatory
ScheduleOfLeasesIndicator	Indicates the existence of a Schedule Of Leases entry in the register	Mandatory
SubChargeIndicator	Indicates the existence of a Sub Charge entry in the register	Mandatory
UnidentifiedEntryIndicator	Indicates whether any entries exist on the register that could not be identified by the system	Mandatory
UnilateralNoticeBeneficiaryIndicator	Indicates the existence of a Unilateral Notice Beneficiary entry in the register	Mandatory
UnilateralNoticeIndicator	Indicates the existence of a Unilateral Notice in the charges register	Mandatory
VendorsLienIndicator	Indicates the existence of a Vendors Lien entry in the register	Mandatory

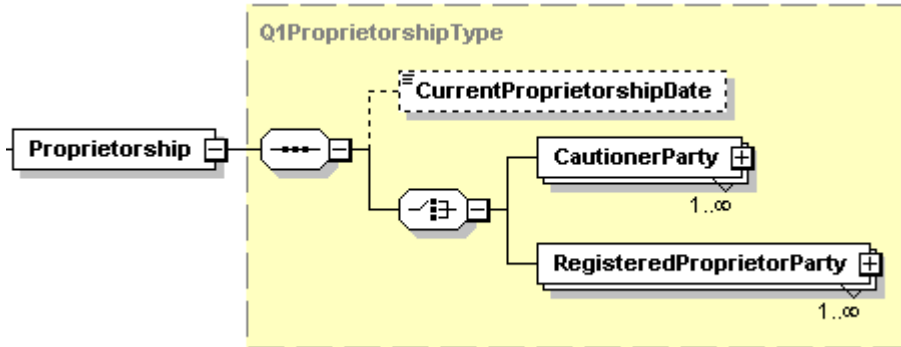

Key elements of the Proprietorship element

The proprietor of an estate can either be a CautionerParty or RegisterProprietorParty. At least one of these elements must exist.

Element	Description	Rules for Use
CurrentProprietorshipDate	The date of the proprietorship entry in the Register	Optional
CautionerParty	The registered proprietor of the estate, when the title is a Caution title.	Optional
RegisteredProprietorParty	The registered proprietor of the estate	Optional

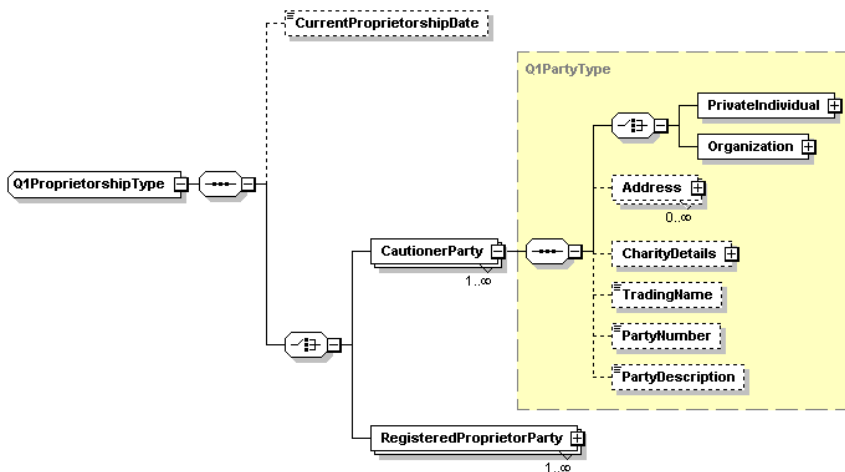

8.1.6 Key elements of the CautionerParty element

Element	Description	Rules for Use
CautionerParty	See Q1PartyType definition for expanded description	Mandatory

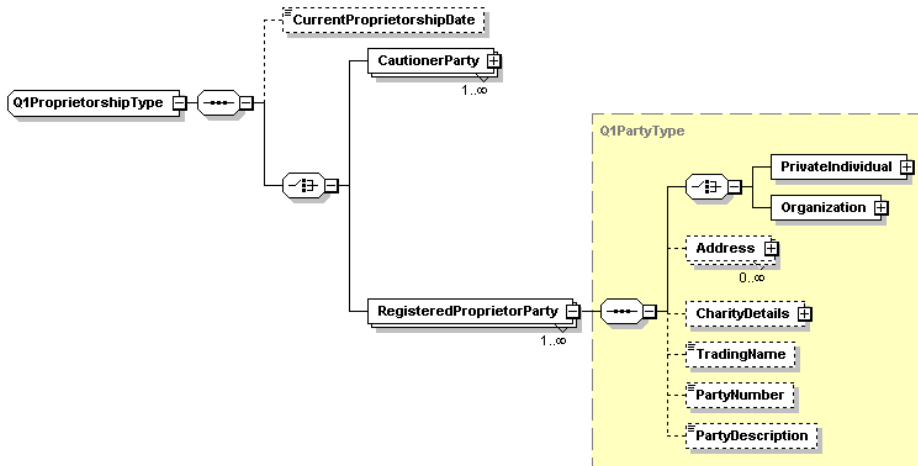

8.1.7 Key elements of the ProprietorParty element

Element	Description	Rules for Use
RegisteredProprietorParty	See Q1PartyType definition for expanded description	Mandatory

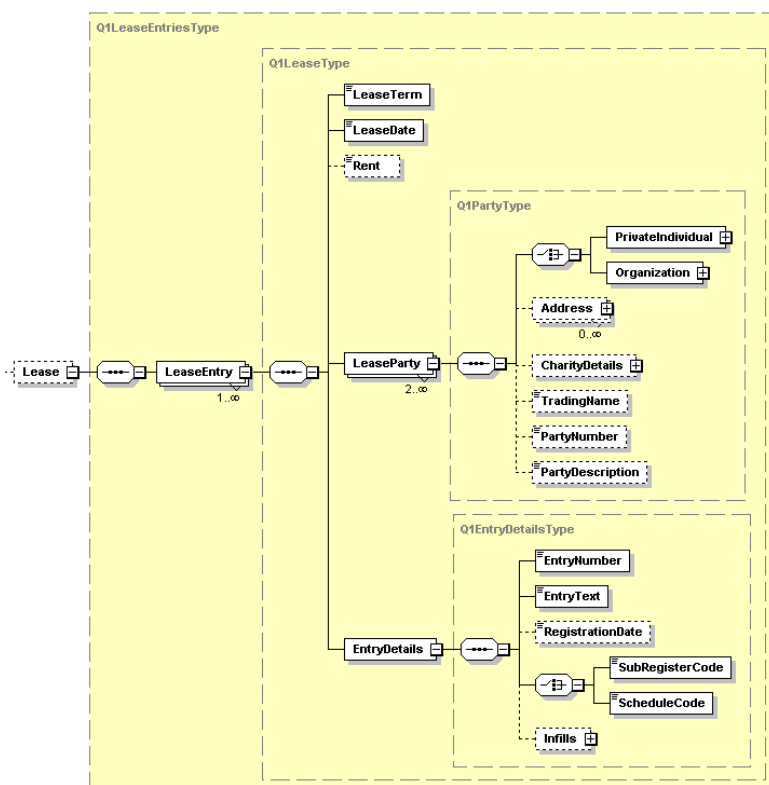

8.1.8 Key elements of the Q1LeaseEntriesType element

Element	Description	Rules for Use
LeaseTerm	The term of the lease including the commencement date (e.g. 125 years from 21 June 2001).	Mandatory



Element	Description	Rules for Use
LeaseDate	Date of the lease.	Mandatory
Rent	The rent amount of the lease. This information does not get entered on the register anymore but will exist on older registers.	Optional
LeaseParty	The names of parties to a lease. Can be individuals or organisations. This element may also contain address details. See Q1PartyType for expanded description.	Mandatory
PartyNumber	Number denoting order of the party	Optional
PartyDescription	The description of the parties that make up a lease that are shown in the H schedule i.e. Lessee and Lessor	Optional
EntryDetails	See Q1EntryDetailsType definition for an expanded description. Types relevant to Q1LeaseEntriesType: EntryNumber EntryText ScheduleCode SubRegisterCode	Mandatory Mandatory Optional Optional

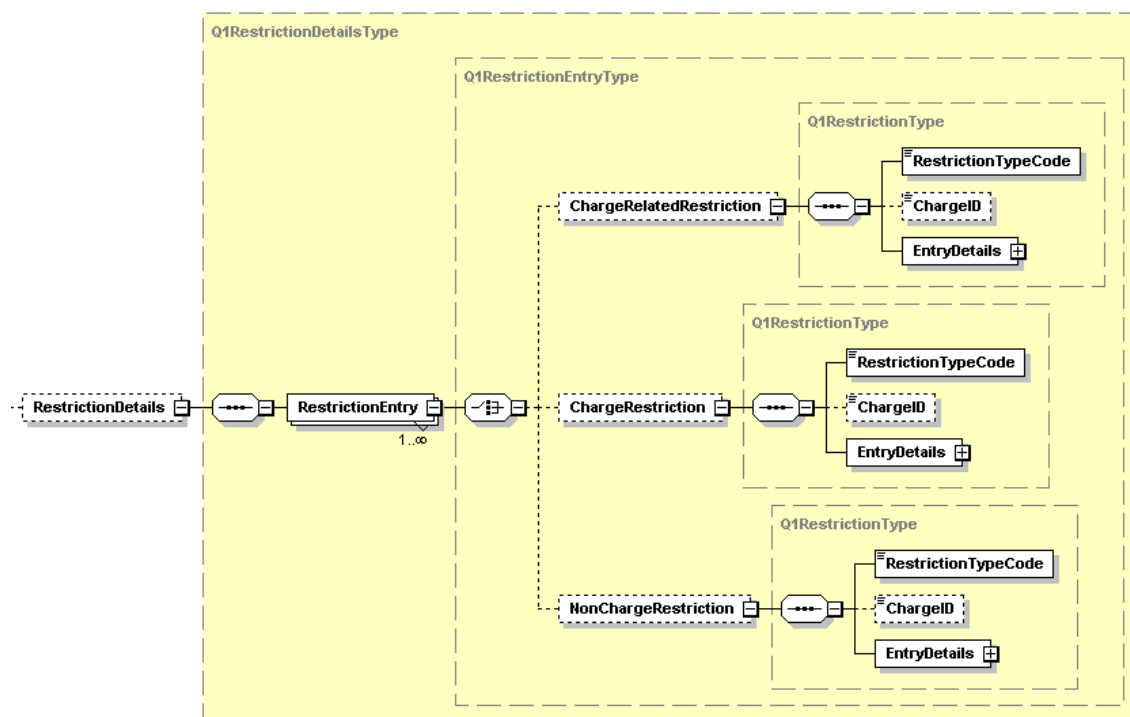

8.1.9 Key elements of the Q1RestrictionEntryType element

The RestrictionDetails is a list containing restriction entries of type Q1RestrictionEntryType.

Element	Description	Rules for Use
RestrictionEntry	List containing details of each restriction entries on the register	Mandatory
ChargeRelatedRestriction	Details of a Charge Related Restriction entry	Optional
ChargeRestriction	Details of a Charge Restriction entry	Optional
NonChargeRestriction	Details of a Non Charge Related Restriction entry	Optional



Element	Description	Rules for Use
RestrictionTypeCode	Type of restriction present on the register. 0 – Other 10 - Joint Proprietor 20 - Charge Related 30 - Charge	Mandatory
ChargeID	A unique identifier linking a charge to a charge proprietor and a restriction entry if it exists.	Optional
EntryDetails	See Q1EntryDetailsType definition for an expanded description. Types relevant to Q1RestrictionType: EntryNumber EntryText ScheduleCode SubRegisterCode	Mandatory Mandatory Optional Optional
Infills	See Q1InfillDetailsType definition for expanded description. Types relevant to ChargeRelatedRestriction: ChargeDate ChargeParty Date MiscellaneousText Name OptionalMiscText Types relevant to ChargeRelatedRestriction: ChargeDate ChargeParty Date MiscellaneousText Name OptionalMiscText Types relevant to NonChargeRestriction: ChargeParty Date MiscellaneousText Name OptionalMiscText TitleNumber	Optional Optional Optional Optional (0..7) Optional (0..2) Optional (0..6) Mandatory Optional Optional Optional Optional Optional (0..2) Optional Optional Optional (0..7) Optional (0..2) Optional (0..7) Optional

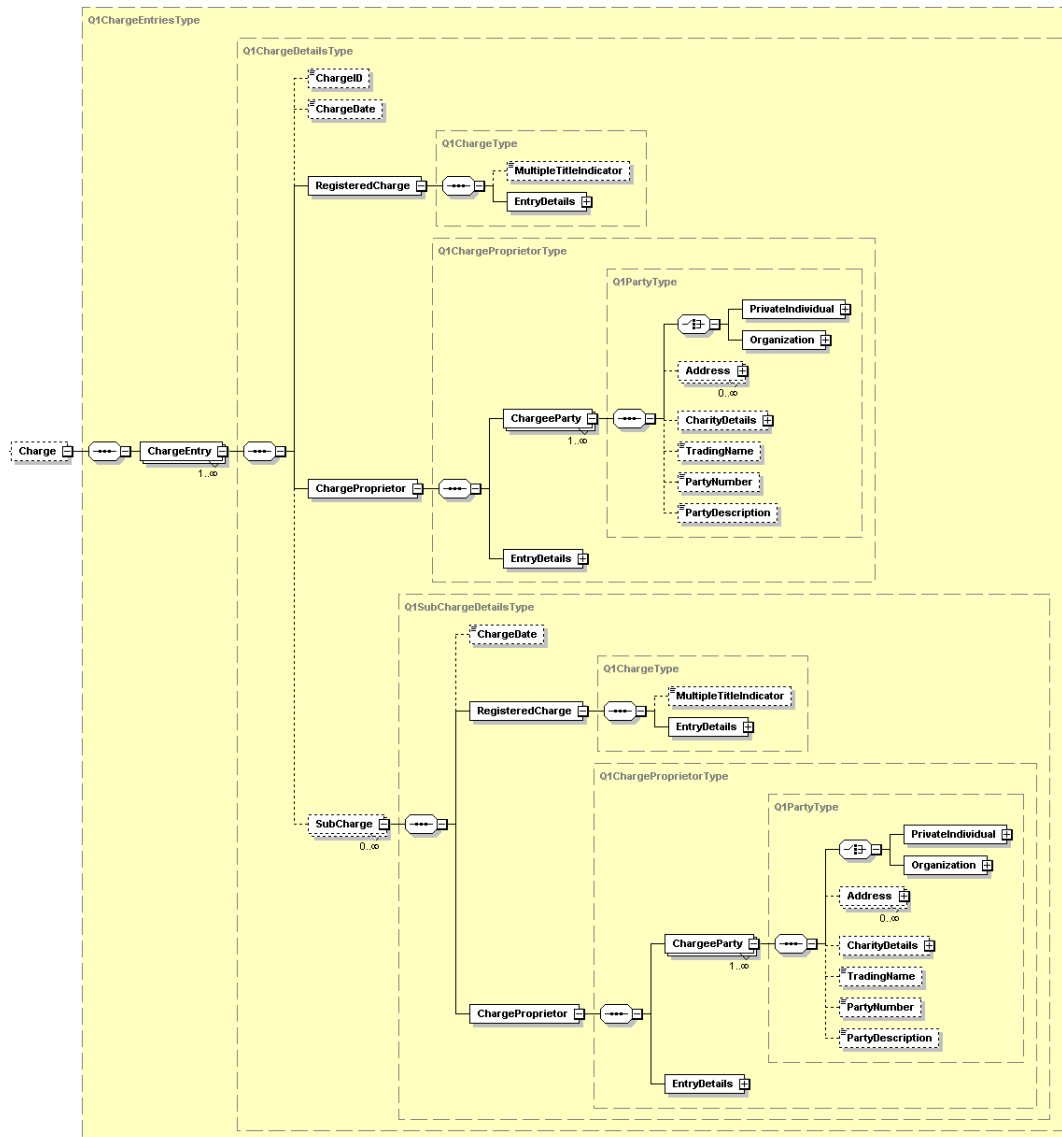

8.1.10 Key elements of the Charge element

Element	Description	Rules for Use
ChargeEntry	List containing details of each charge entry on the register	Mandatory
ChargeID	A unique identifier linking a charge to a charge proprietor and a restriction entry if it exists.	Optional
ChargeDate	The date of the Charge	Optional
RegisteredCharge	Charge entry details	Mandatory
ChargeProprietor	Charge Proprietor entry details	Mandatory
SubCharge	Sub-Charge entry details.	Optional
MultipleTitleIndicator	Indicator showing whether an entry affects other titles	Optional
ChargeeParty	Details of the Chargee. See Q1PartyType for expanded description.	Mandatory



Element	Description	Rules for Use
EntryDetails	See Q1EntryDetailsType definition for an expanded description. Types relevant to Q1ChargeType and Q1ChargeProprietorType: <ul style="list-style-type: none"> EntryNumber EntryText RegistrationDate ScheduleCode SubRegisterCode 	Mandatory Mandatory Optional Optional Optional
Infills	See Q1InfillDetailsType definition for expanded description. Types relevant to Q1ChargeType: <ul style="list-style-type: none"> ChargeDate ChargeParty MiscellaneousText Note OptionalMiscText TitleNumber Types relevant to Q1ChargeProprietorType: <ul style="list-style-type: none"> MiscellaneousText OptionalMiscText 	Optional Optional Optional (0..2) Optional Optional Optional Optional Optional

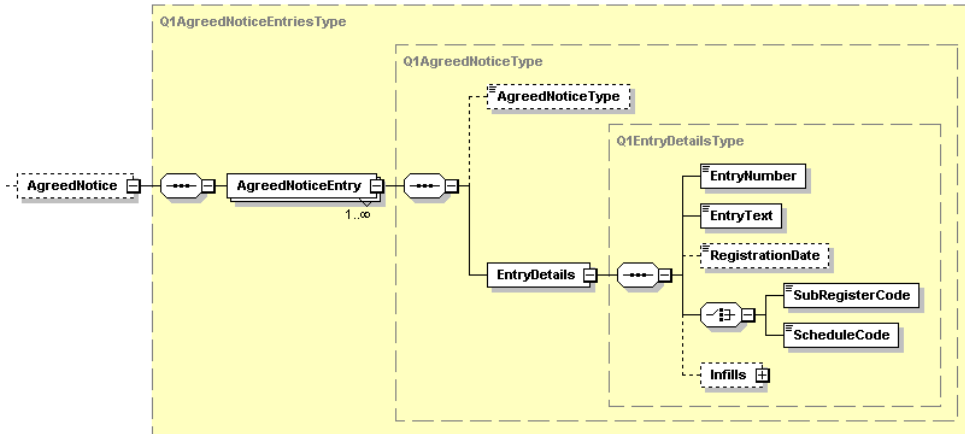

8.1.11 Key elements of the AgreedNotice element

Element	Description	Rules for Use
AgreedNoticeEntry	List containing details of each Agreed Notice entry on the register	Mandatory
AgreedNoticeType	Enumeration type detailing a specific form of Agreed notice. 10 - Option to Purchase 20 - Right of Pre-emption	Optional
EntryDetails	See Q1EntryDetailsType definition for an expanded description. Types relevant to Q1AgreedNoticeType: EntryNumber EntryText ScheduleCode SubRegisterCode	Mandatory Mandatory Optional Optional
Infills	See Q1InfillDetailsType definition for expanded description. Types relevant to Q1AgreedNoticeType: Date DeedDate DeedExtent DeedParty DeedType ExtentOfLand MiscellaneousText Name Note OptionalMiscText VerbatimText	Optional Optional Optional Optional (0..2) Optional Optional Optional (0..2) Optional Optional Optional Optional

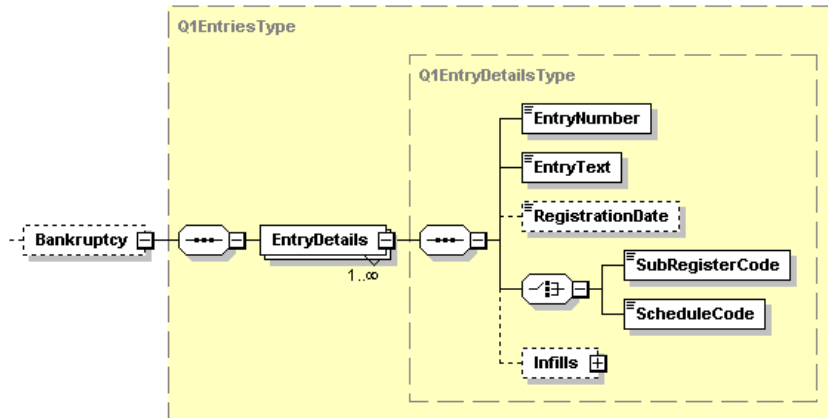

8.1.12 Key elements of the Bankruptcy element

Element	Description	Rules for Use
EntryDetails	List containing details of each Bankruptcy entry on the register. See Q1EntryDetailsType definition for an expanded description. Types relevant to a Bankruptcy entry are: EntryNumber EntryText ScheduleCode SubRegisterCode	Mandatory Mandatory Mandatory Optional Optional
Infills	See Q1InfillDetailsType definition for expanded description. Types relevant to a Bankruptcy entry are: ChargeDate MiscellaneousText Name	Optional Mandatory (3) Mandatory

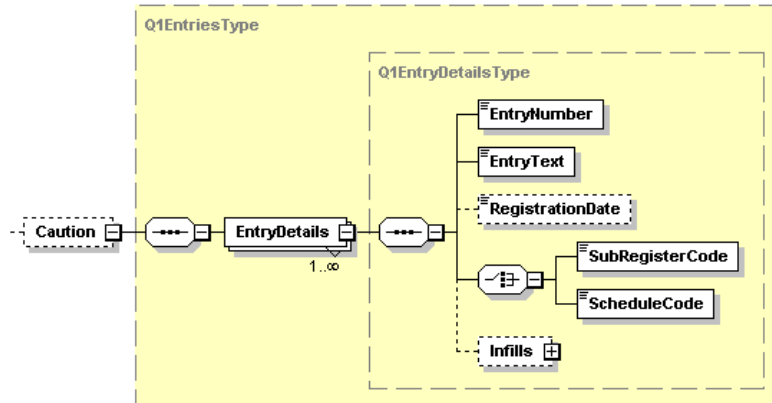

8.1.13 Key elements of the Caution element

Element	Description	Rules for Use
EntryDetails	List containing details of each Caution entry on the register. See Q1EntryDetailsType definition for an expanded description. Types relevant to a Caution entry are: EntryNumber EntryText ScheduleCode SubRegisterCode	Mandatory Mandatory Mandatory Optional Optional
Infills	See Q1InfillDetailsType definition for expanded description. Types relevant to a Caution entry are: Date ExtentOfLand MiscellaneousText Name VerbatimText	Optional Optional Optional (0..2) Optional (0..2) Optional

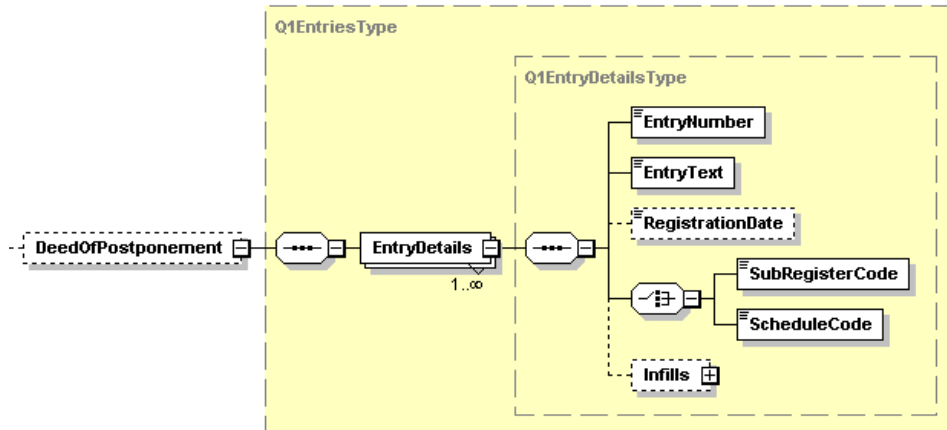

8.1.14 Key elements of the DeedOfPostponement element

Element	Description	Rules for Use
EntryDetails	List containing details of each Deed Of Postponement entry on the register. See Q1EntryDetailsType definition for an expanded description. Types relevant to a Deed Of Postponement entry are: EntryNumber EntryText ScheduleCode SubRegisterCode	Mandatory Mandatory Mandatory Optional Optional
Infills	See Q1InfillDetailsType definition for expanded description. Types relevant to a Deed Of Postponement entry are: ChargeDate Date DeedDate DeedParty MiscellaneousText OptionalMiscText	Optional (0..2) Optional Optional Optional Optional Optional (0..3)

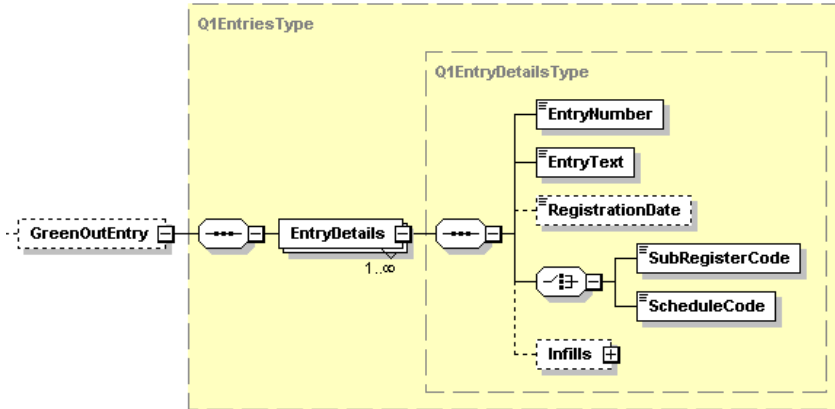

8.1.15 Key elements of the GreenOutEntry element

Element	Description	Rules for Use
EntryDetails	List containing details of each Green Out entry on the register. See Q1EntryDetailsType definition for an expanded description. Types relevant to a Green Out entry are: EntryNumber EntryText ScheduleCode SubRegisterCode	Mandatory Mandatory Mandatory Optional Optional
Infills	See Q1InfillDetailsType definition for expanded description. Types relevant to a Green Out entry are: MiscellaneousText OptionalMiscText TitleNumber	Optional (0..2) Optional Optional

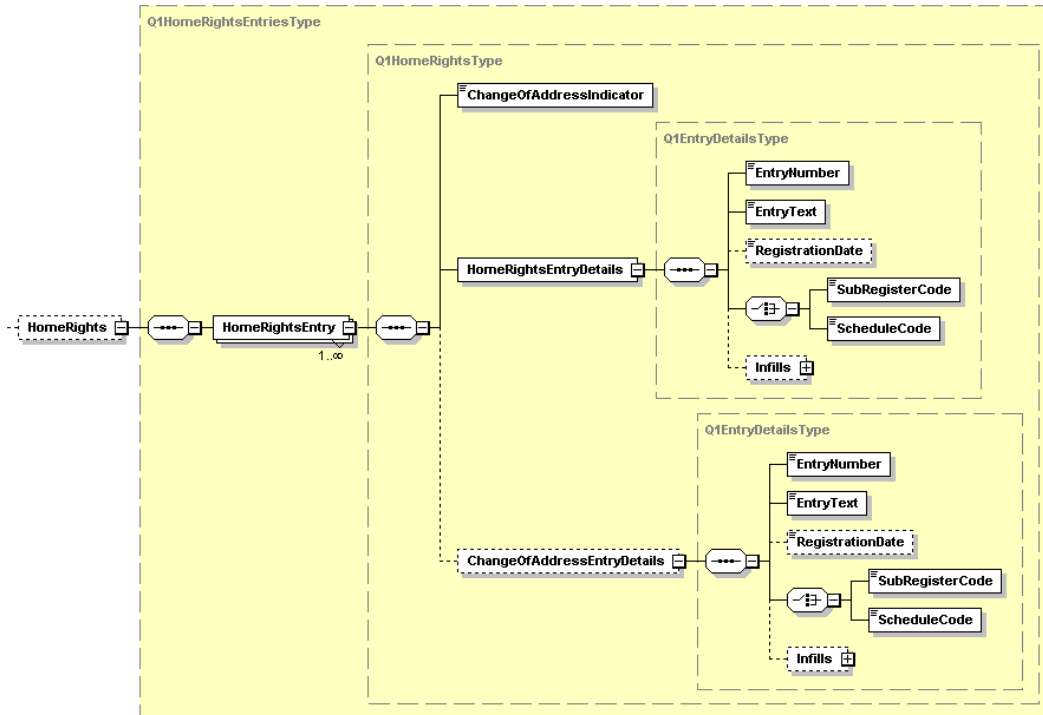

8.1.16 Key elements of the HomeRights element

Element	Description	Rules for Use
HomeRightsEntry	List containing details of each Home rights entry on the register, including Change of Address Home Rights entries	Mandatory
ChangeOfAddressIndicator	Identifies if a Change of Address Entry exists against the Home rights entry. If 'true' a corresponding ChangeOfAddressEntryDetails element will be visible.	Mandatory
HomeRightsEntryDetails	Details of the Home Rights entry	Mandatory
ChangeOfAddressEntryDetails	Details of the Home Rights Change of Address entry	Optional
EntryDetails	See Q1EntryDetailsType definition for an expanded description. Types relevant to a Home Rights entry and Home Rights Change Of Address entry are:	Mandatory
	EntryNumber	Mandatory
	EntryText	Mandatory
	ScheduleCode	Optional
	SubRegisterCode	Optional



Element	Description	Rules for Use
Infills	<p>See Q1InfillDetailsType definition for expanded description. Types relevant to a Home Rights entry and Home Rights Change Of Address entry are:</p> <ul style="list-style-type: none"> Date MiscellaneousText Name OptionalMiscText <p>Types relevant to a Home Rights Change Of Address entry are:</p> <ul style="list-style-type: none"> Name 	<ul style="list-style-type: none"> Optional Optional (0..2) Mandatory (1..2) Optional Mandatory (1)

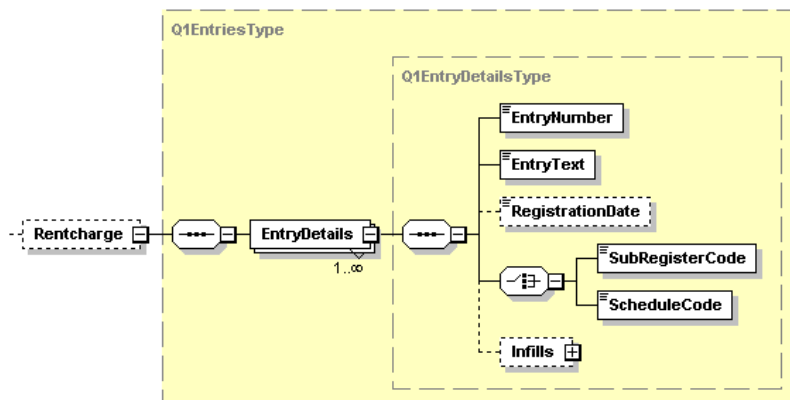

8.1.17 Key elements of the Rentcharge element

Element	Description	Rules for Use
EntryDetails	<p>List containing details of each Rent Charge entry on the register. See Q1EntryDetailsType definition for an expanded description. Types relevant to a Rent Charge entry are:</p> <ul style="list-style-type: none"> EntryNumber EntryText ScheduleCode SubRegisterCode 	<ul style="list-style-type: none"> Mandatory Mandatory Mandatory Optional Optional



Element	Description	Rules for Use
Infills	See Q1InfillDetailsType definition for expanded description. Types relevant to a Rent Charge entry are: Amount DeedDate DeedExtent DeedParty DeedType ExtentOfLand MiscellaneousText Note OptionalMiscText PlansReference	Optional Optional (0..3) Optional (0..3) Optional (0..2) Optional (0..3) Optional Optional (0..3) Optional Optional Optional

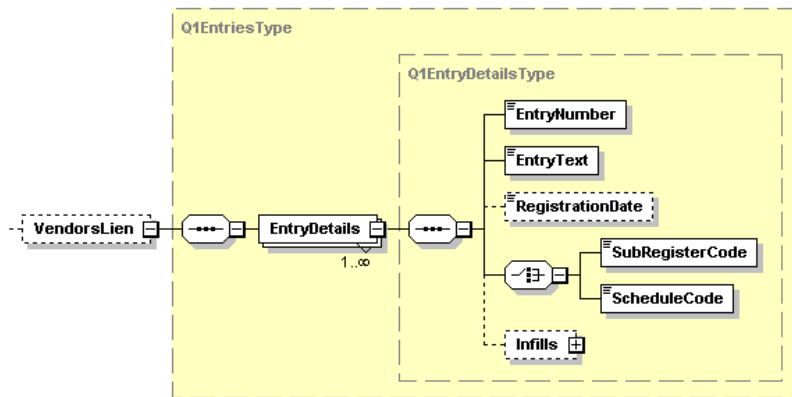

8.1.18 Key elements of the VendorsLien element

Element	Description	Rules for Use
EntryDetails	List containing details of each Vendors Lien entry on the register. See Q1EntryDetailsType definition for an expanded description. Types relevant to a Vendors Lien entry are: EntryNumber EntryText ScheduleCode SubRegisterCode	Mandatory Mandatory Mandatory Optional Optional
Infills	See Q1InfillDetailsType definition for expanded description. Types relevant to a Vendors Lien entry are: DeedDate DeedParty MiscellaneousText Note	Optional Optional Optional Optional

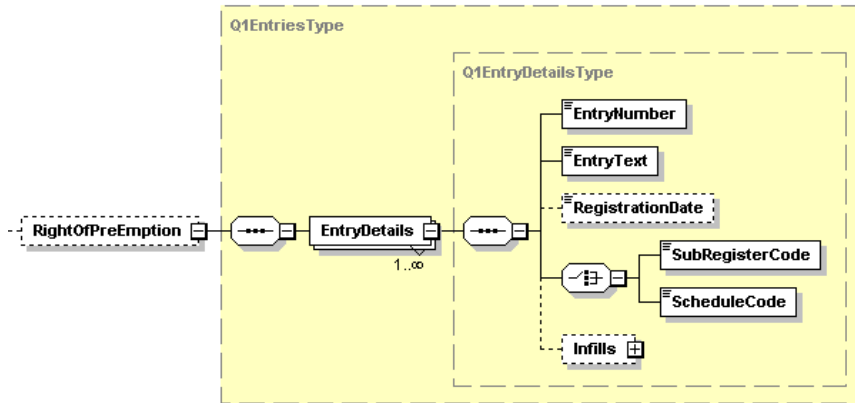

8.1.19 Key elements of the RightOfPreEmption element

Element	Description	Rules for Use
EntryDetails	List containing details of each Right Of Pre-emption entry on the register. See Q1EntryDetailsType definition for an expanded description. Types relevant to a Right Of Pre-emption entry are: EntryNumber EntryText ScheduleCode SubRegisterCode	Mandatory Mandatory Mandatory Optional Optional
Infills	See Q1InfillDetailsType definition for expanded description. Types relevant to a Right Of Pre-emption entry are: Date DeedDate DeedExtent DeedType Name OptionalMiscText	Mandatory Mandatory Mandatory Mandatory Mandatory Optional

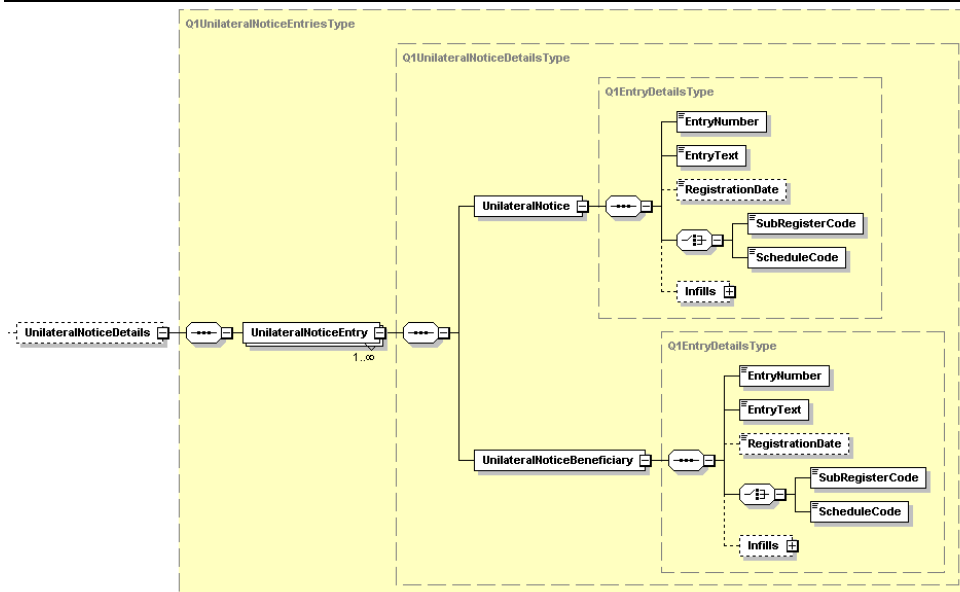

8.1.20 Key elements of the UnilateralNoticeDetails element



Element	Description	Rules for Use
UnilateralNoticeEntry	List containing Q1UnilateralNoticeDetailsType elements that consist of a UnilateralNotice and UnilateralNoticeBeneficiary entries.	Mandatory
UnilateralNotice	Details of the Unilateral Notice entry	Mandatory
UnilateralNoticeBeneficiary	Details of the Unilateral Notice Beneficiary entry	Mandatory
EntryDetails	See Q1EntryDetailsType definition for an expanded description. Types relevant to a Unilateral Notice entry and Unilateral Notice Beneficiary entry are: EntryNumber EntryText ScheduleCode SubRegisterCode	Mandatory Mandatory Optional Optional
Infills	See Q1InfillDetailsType definition for expanded description. Types relevant to a Unilateral Notice entry: ChargeDate ExtentOfLand MiscellaneousText Note OptionalMiscText Types relevant to a Unilateral Notice Beneficiary entry: MiscellaneousText Name	Optional Mandatory Mandatory Optional Mandatory Mandatory Mandatory

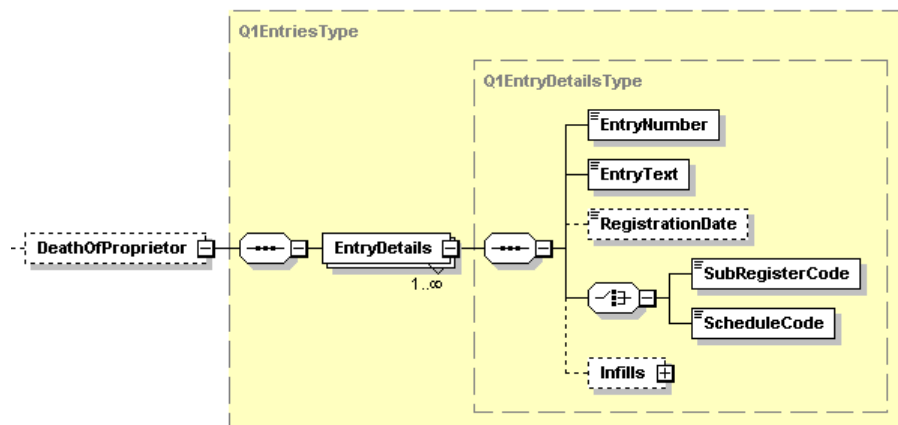

8.1.21 Key elements of the DeathOfProprietor element

Element	Description	Rules for Use
EntryDetails	List containing details of each Death of Proprietor entry on the register. See Q1EntryDetailsType definition for an expanded description. Types relevant to a Death of Proprietor entry are: EntryNumber EntryText ScheduleCode SubRegisterCode	Mandatory Mandatory Mandatory Optional Optional

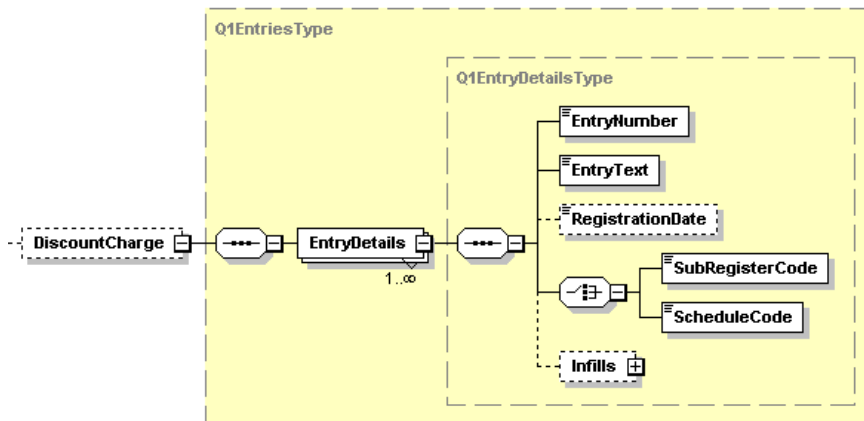

8.1.22 Key elements of the DiscountCharge element

Element	Description	Rules for Use
EntryDetails	List containing details of each Discount Charge entry on the register. See Q1EntryDetailsType definition for an expanded description. Types relevant to a Discount Charge entry are: EntryNumber EntryText ScheduleCode SubRegisterCode	Mandatory Mandatory Mandatory Optional Optional
Infills	See Q1InfillDetailsType definition for expanded description. Types relevant to a Discount Charge entry are: ChargeDate Date MiscellaneousText Name Note	Optional Optional Optional (0..3) Optional Optional

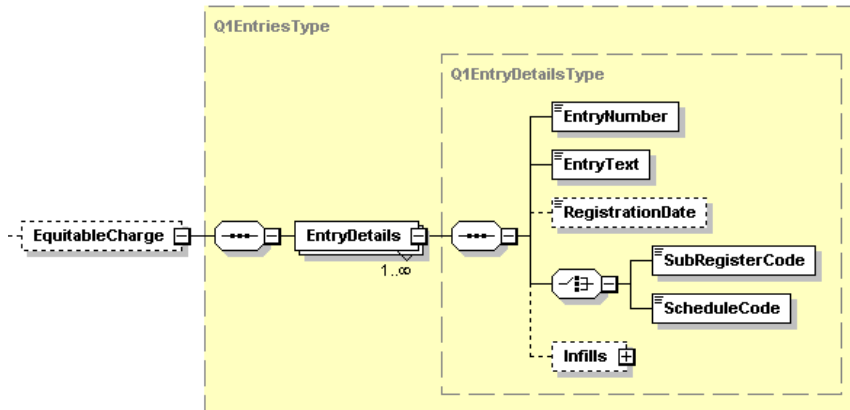

8.1.23 Key elements of the EquitableCharge element

Element	Description	Rules for Use
EntryDetails	List containing details of each Equitable Charge entry on the register. See Q1EntryDetailsType definition for an expanded description. Types relevant to a Equitable Charge entry are: EntryNumber EntryText ScheduleCode SubRegisterCode	Mandatory Mandatory Mandatory Optional Optional
Infills	See Q1InfillDetailsType definition for expanded description. Types relevant to a Equitable Charge entry are: ChargeDate Date DeedDate DeedExtent DeedType MiscellaneousText Name Note OptionalMiscText TitleNumber	Optional Optional Optional Optional Optional Optional (0..2) Optional Optional Optional Optional

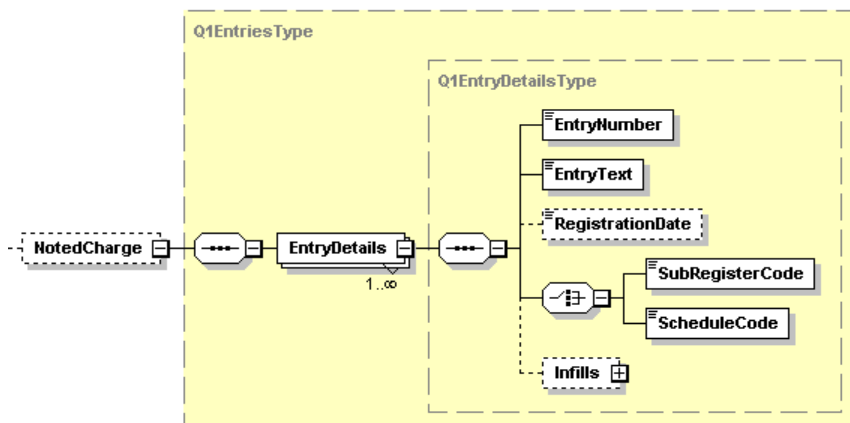



8.1.24 Key elements of the NotedCharge element

Element	Description	Rules for Use
EntryDetails	List containing details of each Noted Charge entry on the register. See Q1EntryDetailsType definition for an expanded description. Types relevant to a Noted Charge entry are: EntryNumber EntryText ScheduleCode SubRegisterCode	Mandatory Mandatory Mandatory Optional Optional
Infills	See Q1InfillDetailsType definition for expanded description. Types relevant to a Noted Charge entry are: ChargeDate DeedDate DeedParty ExtentOfLand MiscellaneousText Name Note	Mandatory Optional Optional Optional Optional Optional Optional

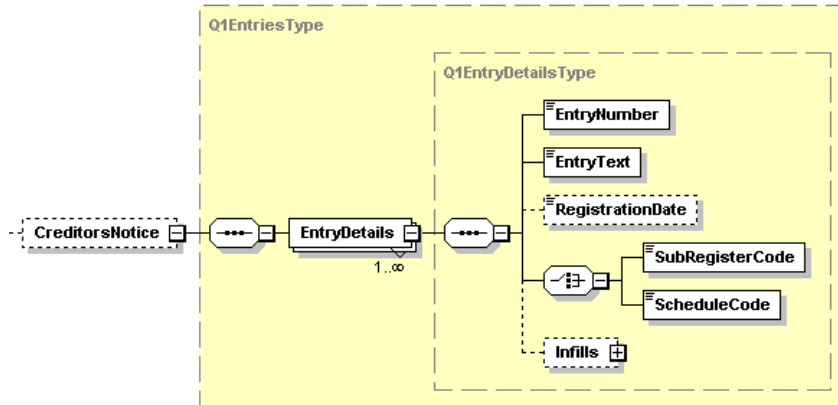

8.1.25 Key elements of the CreditorsNotice element

Element	Description	Rules for Use
EntryDetails	List containing details of each Creditors Notice entry on the register. See Q1EntryDetailsType definition for an expanded description. Types relevant to a Creditors Notice entry are: EntryNumber EntryText ScheduleCode SubRegisterCode	Mandatory Mandatory Mandatory Optional Optional
Infills	See Q1InfillDetailsType definition for expanded description. Types relevant to a Creditors Notice entry are: MiscellaneousText Name	Mandatory (3) Mandatory (1)

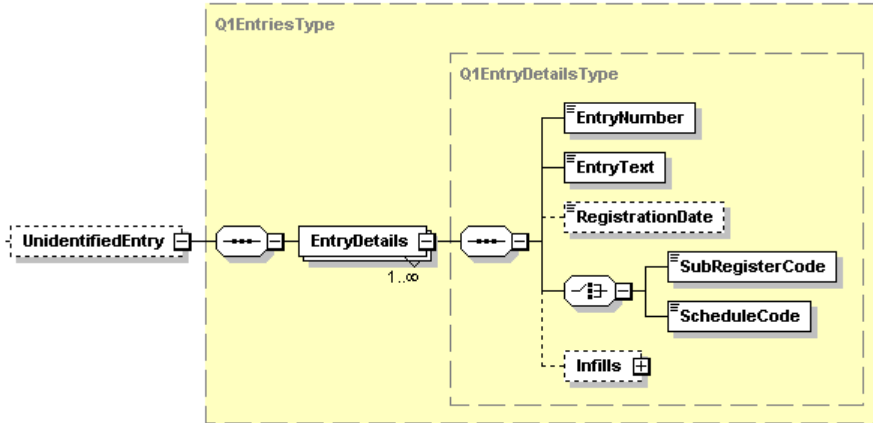

8.1.26 Key elements of the UnidentifiedEntry element

Element	Description	Rules for Use
EntryDetails	List containing details of each Unidentified entry on the register. See Q1EntryDetailsType definition for an expanded description. Types relevant to a Unidentified entry are:	Mandatory
	EntryNumber	Mandatory
	EntryText	Mandatory
	ScheduleCode	Optional
	SubRegisterCode	Optional

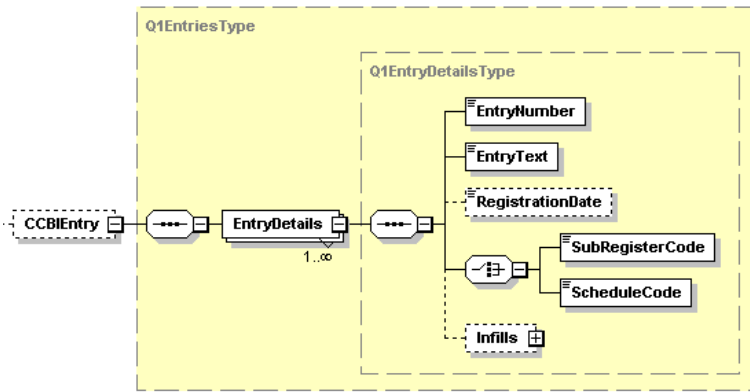

8.1.27 Key elements of the CCBIEntry element

Element	Description	Rules for Use
EntryDetails	List containing details of each Cautions/Creditor Notice/Bankruptcy/Inhibition entry on the register. See Q1EntryDetailsType definition for an expanded description. Types relevant to a Cautions/Creditor Notice/Bankruptcy/Inhibition entry are: EntryNumber EntryText ScheduleCode SubRegisterCode	Mandatory Mandatory Mandatory Optional Optional
Infills	See Q1InfillDetailsType definition for expanded description. Types relevant to a Cautions/Creditor Notice/Bankruptcy/Inhibition entry are: ChargeDate ChargeParty MiscellaneousText Name	Optional Optional Optional (0..5) Optional

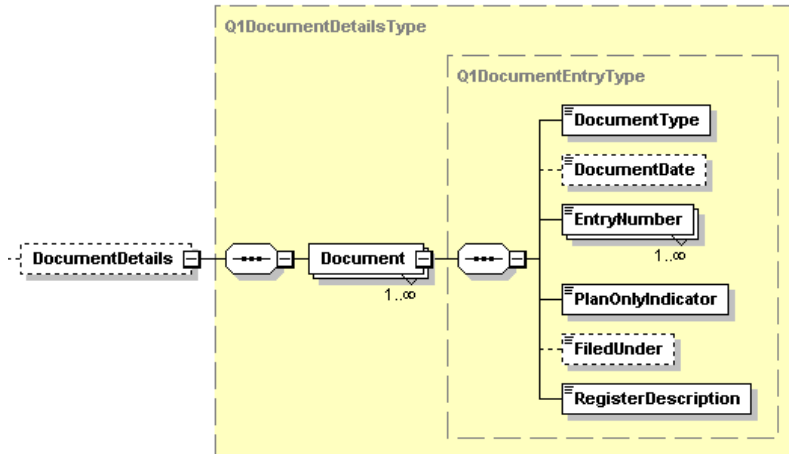

8.1.28 Key elements of the DocumentDetails element

Element	Description	Rules for Use
Document	List of documents referred to on the register.	Mandatory
DocumentType	The type of document referred to in the register. 10 - Abstract 20 - Agreement 30 - Assent 40 - Assignment 50 - Charge 60 - Conveyance 70 - Deed 80 - Indenture 90 - Lease 100 - Licence 110 - Plan 120 - Sub-Charge 130 - Transfer 140 - Other 150 - Commonhold Community Statement 160 - Memorandum and Articles of Association 170 - Surrender of Development Rights 180 - Termination Document	Mandatory
DocumentDate	The date of the document referred to in the register	Optional
EntryNumber	The letter and entry number within the relevant Sub-Register or Schedule	Mandatory
PlanOnlyIndicator	Indicator showing whether the document is only held as a plan	Mandatory
FiledUnder	Displays the title number the document is filed under	Optional
RegisterDescription	The full description of the document as it appears on the register	Mandatory

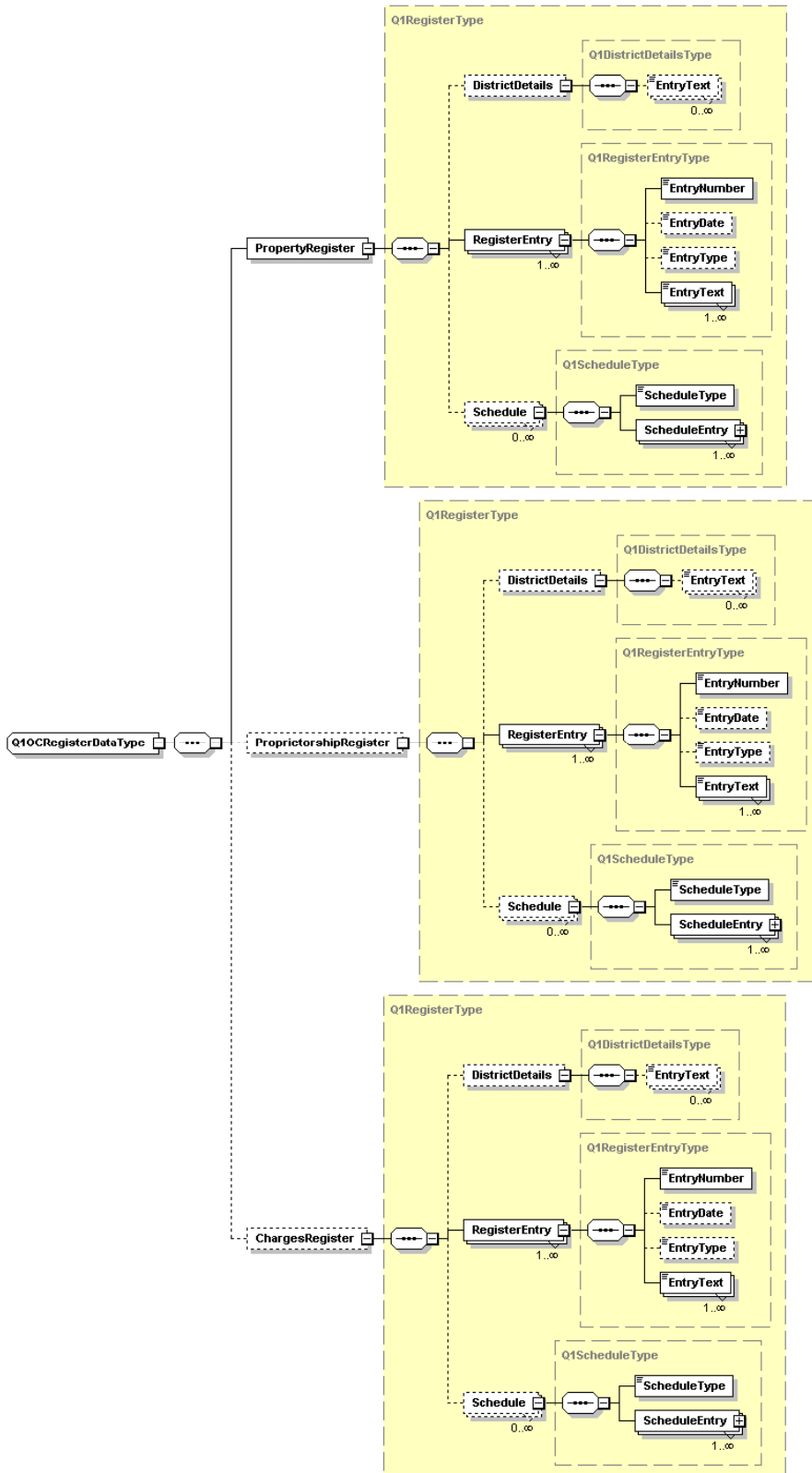

8.1.29 Key elements of the OCRegisterData element

HM Land Registry

Interface Specification



Element	Description	Rules for Use
PropertyRegister	A - Register	Mandatory
ProprietorshipRegister	B - Register	Optional
ChargesRegister	C - Register	Optional
DistrictDetails	Element containing district information associated with the property	Optional
RegisterEntry	Element containing entry details	Mandatory
Schedule	Element containing schedule details	Optional
EntryText	Details of the entry. Unformatted.	Mandatory
EntryNumber	The entry number within the relevant Sub-Register or Schedule	Mandatory
EntryType	Identifies the type of entry the entry text relates to.	Optional
EntryDate	Date when the entry was inputted on the register.	Optional
ScheduleType	Identifies the type of entry the schedule text relates to	Mandatory
ScheduleEntry	Element containing schedule entry details.	Mandatory



9 Glossary or terms and abbreviations

RES	Register Extract Service
OC	Official Copy
HTTP	HyperText Transfer Protocol
PDF	Portable Document Format
URL	Universal Resource Locator
XML	eXtensible Markup Language
ZIP	ZIP File Format

10 Annex A

XML Schemas are compliant with e-GIF (Electronic Government Interoperability Framework) standards.

Schema files are named according to the standard *<filename>-vm-n.xsd* where *v* is the letter 'v', *m* is the major version number and *n* is the minor version number.

HM Land Registry

Interface Specification



RequestOCWithSummaryV2_0.xsd

```
<?xml version="1.0" encoding="UTF-8"?>
<xs:schema xmlns:xs="http://www.w3.org/2001/XMLSchema"
  xmlns="http://www.oscre.org/ns/eReg-Final/2011/RequestOCWithSummaryV2_0"
  targetNamespace="http://www.oscre.org/ns/eReg-Final/2011/RequestOCWithSummaryV2_0"
  elementFormDefault="qualified"
  attributeFormDefault="unqualified">
  <xs:annotation>
    <xs:documentation>This is the Business Gateway request for the OC with Summary service.</xs:documentation>
  </xs:annotation>
  <!--Document-->
  <xs:element name="RequestOCWithSummaryV2_0"
    type="RequestOCWithSummaryV2_0Type"/>
  <!--ABIEs-->
  <xs:complexType name="Q1CustomerReferenceType">
    <xs:annotation>
      <xs:documentation>Provides a unique reference to identify a particular request, order or instruction or object in
the system of the organisation allocating it.</xs:documentation>
    </xs:annotation>
    <xs:sequence>
      <xs:element name="Reference"
        type="ReferenceTextContentType"
        minOccurs="1"
        maxOccurs="1">
        <xs:annotation>
          <xs:documentation>A unique reference given to identify a particular request, order or
instruction in the system of the organisation allocating it.</xs:documentation>
        </xs:annotation>
      </xs:element>
      <xs:element name="AllocatedBy"
        type="Q3TextType"
        minOccurs="0"
        maxOccurs="1">
        <xs:annotation>
          <xs:documentation>The name of the organisation that has allocated the
Reference</xs:documentation>
        </xs:annotation>
      </xs:element>
      <xs:element name="Description"
        type="Q3TextType"
        minOccurs="0"
        maxOccurs="1">
        <xs:annotation>
          <xs:documentation>This field can be used to provide reference description</xs:documentation>
        </xs:annotation>
      </xs:element>
    </xs:sequence>
  </xs:complexType>
  <xs:complexType name="Q1ExpectedPriceType">
    <xs:annotation>
      <xs:documentation>Information about price</xs:documentation>
    </xs:annotation>
    <xs:sequence>
      <xs:element name="GrossPriceAmount"
        type="AmountType"
        minOccurs="0"
        maxOccurs="1">
        <xs:annotation>
          <xs:documentation>The gross price is the price including the VAT.
If the VAT is zero then the Gross and Net Price will be the same</xs:documentation>
        </xs:annotation>
      </xs:element>
      <xs:element name="NetPriceAmount"
        type="AmountType"
        minOccurs="0"
        maxOccurs="1">
        <xs:annotation>
          <xs:documentation>The Net Price is the amount before the VAT is added on.
If the VAT is zero then the Gross and Net Price will be the same</xs:documentation>
        </xs:annotation>
      </xs:element>
      <xs:element name="VATAmount"
        type="AmountType"
        minOccurs="0"
        maxOccurs="1">
        <xs:annotation>
          <xs:documentation>This is the amount of the VAT</xs:documentation>
        </xs:annotation>
      </xs:element>
    </xs:sequence>
  </xs:complexType>
  <xs:complexType name="Q1ExternalReferenceType">
    <xs:annotation>
      <xs:documentation>A unique reference given to identify a particular request, order or instruction in the system of
the organisation allocating it with the ability to associate the name of the Company that has allocated it.</xs:documentation>
    </xs:annotation>
    <xs:sequence>
      <xs:element name="Reference"
        type="ReferenceTextContentType"
        minOccurs="1"
        maxOccurs="1">
        <xs:annotation>
          <xs:documentation>A unique reference given to identify a particular request, order or
instruction in the system of the organisation allocating it.</xs:documentation>
        </xs:annotation>
      </xs:element>
      <xs:element name="AllocatedBy"
        type="Q3TextType"
        minOccurs="0"
        maxOccurs="1">
        <xs:annotation>
          <xs:documentation>The name of the organisation that has allocated the
Reference</xs:documentation>
        </xs:annotation>
      </xs:element>
    </xs:sequence>
  </xs:complexType>
```

HM Land Registry

Interface Specification



```
</xs:element>
<xs:element name="Description"
  type="Q3TextType"
  minOccurs="0"
  maxOccurs="1">
  <xs:annotation>
    <xs:documentation>This field can be used to provide reference description</xs:documentation>
  </xs:annotation>
</xs:element>
</xs:sequence>
</xs:complexType>
<xs:complexType name="Q1IdentifierType">
  <xs:sequence>
    <xs:element name="MessageID"
      type="Q1TextType"
      minOccurs="1"
      maxOccurs="1">
      <xs:annotation>
        <xs:documentation>A character string (i.e. a finite set of characters) generally in the form of
words of a language.</xs:documentation>
      </xs:annotation>
    </xs:element>
  </xs:sequence>
</xs:complexType>
<xs:complexType name="Q1ProductType">
  <xs:annotation>
    <xs:documentation>This component contains details regarding the search being ordered, expedited service, price
details, delivery method and any attachment.</xs:documentation>
  </xs:annotation>
  <xs:sequence>
    <xs:element name="SubjectProperty"
      type="Q1SubjectPropertyType"
      minOccurs="1"
      maxOccurs="1">
      <xs:annotation>
        <xs:documentation>The Property which is the subject of the transaction, or on which a search is
being prepared</xs:documentation>
      </xs:annotation>
    </xs:element>
    <xs:element name="ExpectedPrice"
      type="Q1ExpectedPriceType"
      minOccurs="0"
      maxOccurs="1">
      <xs:annotation>
        <xs:documentation>Information about price</xs:documentation>
      </xs:annotation>
    </xs:element>
    <xs:element name="ExternalReference"
      type="Q1ExternalReferenceType"
      minOccurs="1"
      maxOccurs="1">
      <xs:annotation>
        <xs:documentation>Reference associated with a case in Case Management System</xs:documentation>
      </xs:annotation>
    </xs:element>
    <xs:element name="CustomerReference"
      type="Q1CustomerReferenceType"
      minOccurs="1"
      maxOccurs="1">
      <xs:annotation>
        <xs:documentation>Reference of the person for whom the remortgage is
performed.</xs:documentation>
      </xs:annotation>
    </xs:element>
    <xs:element name="TitleKnownOfficialCopy"
      type="Q1TitleKnownOfficialCopyType"
      minOccurs="1"
      maxOccurs="1">
      <xs:annotation>
        <xs:documentation>The ability for the [External System] to submit a request for an official
copy using the title number. This includes requesting official copy of the Register / Title Plan / Certificate in form CI (OC1) or
other documents (OC2) associated with the title.</xs:documentation>
      </xs:annotation>
    </xs:element>
  </xs:sequence>
</xs:complexType>
<xs:complexType name="Q1SubjectPropertyType">
  <xs:annotation>
    <xs:documentation>The Property which is the subject of the transaction.</xs:documentation>
  </xs:annotation>
  <xs:sequence>
    <xs:element name="TitleNumber"
      type="Q2TextType"
      minOccurs="1"
      maxOccurs="1">
      <xs:annotation>
        <xs:documentation>Provides the subject property title
number if known</xs:documentation>
      </xs:annotation>
    </xs:element>
  </xs:sequence>
</xs:complexType>
<xs:complexType name="Q1TitleKnownOfficialCopyType">
  <xs:sequence>
    <xs:element name="ContinueIfTitleIsClosedAndContinuedIndicator"
      type="IndicatorType"
      minOccurs="1"
      maxOccurs="1"
      default="false">
      <xs:annotation>
        <xs:documentation>
          An indicator sent by the CMS to the BG to advise
          whether to continue with the new Title number
          without warning.
        </xs:documentation>
      </xs:annotation>
    </xs:element>
  </xs:sequence>
</xs:complexType>
```

HM Land Registry

Interface Specification



```
</xs:element>
<xs:element name="NotifyIfPendingFirstRegistrationIndicator"
  type="IndicatorType"
  minOccurs="1"
  maxOccurs="1"
  default="false">
  <xs:annotation>
    <xs:documentation>
      A list of two mutually exclusive Boolean values
      that express the only possible states of a
      Property.
      Please note that this value will always be treated as
      being set to false by HMLR
    </xs:documentation>
  </xs:annotation>
</xs:element>
<xs:element name="NotifyIfPendingApplicationIndicator"
  type="IndicatorType"
  minOccurs="1"
  maxOccurs="1"
  default="false">
  <xs:annotation>
    <xs:documentation>
      A list of two mutually exclusive Boolean values
      that express the only possible states of a
      Property.
      Please note that this value will always be treated as
      being set to false by HMLR
    </xs:documentation>
  </xs:annotation>
</xs:element>
<xs:element name="SendBackDatedIndicator"
  type="IndicatorType"
  minOccurs="1"
  maxOccurs="1"
  default="false">
  <xs:annotation>
    <xs:documentation>
      A list of two mutually exclusive Boolean values
      that express the only possible states of a
      Property.
    </xs:documentation>
  </xs:annotation>
</xs:element>
<xs:element name="ContinueIfActualFeeExceedsExpectedFeeIndicator"
  type="IndicatorType"
  minOccurs="1"
  maxOccurs="1"
  default="false">
  <xs:annotation>
    <xs:documentation>
      A list of two mutually exclusive Boolean values
      that express the only possible states of a
      Property.
    </xs:documentation>
  </xs:annotation>
</xs:element>
<xs:element name="IncludeTitlePlanIndicator"
  type="IndicatorType"
  maxOccurs="1"
  minOccurs="1"/>
</xs:sequence>
</xs:complexType>
<xs:complexType name="RequestOCWithSummaryV2_0Type">
  <xs:annotation>
    <xs:documentation>
```

This document provides the ability for the [External System] to submit a request for an official copy using the title number. This includes requesting official copy of the Register / Title Plan / Certificate in form CI (OC1) or other documents referred to in the Register that have not been designated exempt (OC2) associated with the title.

If the chosen method of delivery is 'electronic', the requested official copy is made available to the user in a suitable electronic format (PDF) if the official copy can be provided electronically. However if an electronic version of the official copy cannot be supplied, an official copy will be sent through the post. If the chosen method of delivery is 'postal', the requested official copy is sent by post.

If the External System has requested more than one type of official copy and selected the delivery method as 'electronic', Land Registry System will deliver electronic versions only if all the requested official copy types are available electronically. For

HM Land Registry

Interface Specification



example, if Register and Title Plan are requested electronically, and Register cannot be provided electronically, both Register and Title Plan will be sent by post.

```
</xs:documentation>
</xs:annotation>
<xs:sequence>
  <xs:element name="ID"
    type="Q1IdentifierType"
    minOccurs="1"
    maxOccurs="1"/>
  <xs:element name="Product"
    type="Q1ProductType"
    minOccurs="1"
    maxOccurs="1">
    <xs:annotation>
      <xs:documentation>This component contains details regarding the search being ordered, expedited
service, price details, delivery method and any attachment</xs:documentation>
    </xs:annotation>
  </xs:element>
</xs:sequence>
</xs:complexType>
<!--Datatypes-->
<xs:complexType name="IndicatorType">
  <xs:annotation>
    <xs:documentation>A list of two mutually exclusive Boolean values that express the only possible states of a
Property.</xs:documentation>
  </xs:annotation>
  <xs:simpleContent>
    <xs:extension base="xs:boolean"/>
  </xs:simpleContent>
</xs:complexType>
<xs:complexType name="Q1TextType">
  <xs:annotation>
    <xs:documentation>A character string (i.e. a finite set of characters) generally in the form of words of a
language.</xs:documentation>
  </xs:annotation>
  <xs:simpleContent>
    <xs:extension base="Q1TextContentType"/>
  </xs:simpleContent>
</xs:complexType>
<xs:complexType name="Q2TextType">
  <xs:annotation>
    <xs:documentation>A character string (i.e. a finite set of
characters) generally in the form of words of a language.
  </xs:documentation>
  </xs:annotation>
  <xs:simpleContent>
    <xs:extension base="Q2TextContentType"/>
  </xs:simpleContent>
</xs:complexType>
<xs:complexType name="Q3TextType">
  <xs:annotation>
    <xs:documentation>A character string (i.e. a finite set of
characters) generally in the form of words of a language.
  </xs:documentation>
  </xs:annotation>
  <xs:simpleContent>
    <xs:extension base="Q3TextContentType"/>
  </xs:simpleContent>
</xs:complexType>
<!--Contenttypes-->
<xs:simpleType name="CustomerReferenceTextContentType">
  <xs:restriction base="xs:string">
    <xs:minLength value="1"/>
    <xs:maxLength value="25"/>
    <xs:pattern value="[A-Za-z0-9\s~!&quot;@#%&'()*+,-\./:;=&lt;?[\ ]_{}^&#xa3;&amp;]*"/>
  </xs:restriction>
</xs:simpleType>
<xs:simpleType name="ERegAmountContentType">
  <xs:restriction base="xs:decimal">
    <xs:maxInclusive value="10000000"/>
    <xs:minInclusive value="0"/>
  </xs:restriction>
</xs:simpleType>
<xs:complexType name="AmountType">
  <xs:annotation>
    <xs:documentation>A number of monetary units specified in a currency
where the unit of the currency is explicit or implied.
  </xs:documentation>
  </xs:annotation>
  <xs:simpleContent>
    <xs:extension base="xs:decimal">
      <xs:attribute name="currencyID"
        type="xs:normalizedString"
        use="optional">
        <xs:annotation>
          <xs:documentation>The currency of the amount</xs:documentation>
        </xs:annotation>
      </xs:attribute>
    </xs:extension>
  </xs:simpleContent>
</xs:complexType>
<xs:simpleType name="ReferenceTextContentType">
  <xs:restriction base="xs:string">
    <xs:minLength value="1"/>
    <xs:maxLength value="25"/>
    <xs:pattern value="[A-Za-z0-9\s~!&quot;@#%&'()*+,-\./:;=&lt;?[\ ]_{}^&#xa3;&amp;]*"/>
  </xs:restriction>
</xs:simpleType>
<xs:simpleType name="Q1TextContentType">
  <xs:restriction base="xs:string">
    <xs:minLength value="5"/>
    <xs:maxLength value="50"/>
    <xs:pattern value="[a-zA-Z0-9][a-zA-Z0-9-]*"/>
  </xs:restriction>
</xs:simpleType>
<xs:simpleType name="Q2TextContentType">
```

HM Land Registry

Interface Specification



```
<xs:restriction base="xs:string">
  <xs:minLength value="1"/>
  <xs:maxLength value="9"/>
  <xs:pattern value="[A-Z]{0,3}[0-9]{1,6}[ZT]?"/>
</xs:restriction>
</xs:simpleType>
<xs:simpleType name="Q3TextContentType">
  <xs:restriction base="xs:string">
    <xs:pattern value=".*\S.*"/>
  </xs:restriction>
</xs:simpleType>
</xs:schema>
```

HM Land Registry

Interface Specification



ResponseOCWithSummaryV2_1.xsd

```
<?xml version="1.0" encoding="UTF-8"?>
<ResponseOCWithSummaryV2_1 xmlns="http://www.oscre.org/ns/eReg-Final/2011/ResponseOCWithSummaryV2_1"
xmlns:xsi="http://www.w3.org/2001/XMLSchema-instance" xsi:schemaLocation="http://www.oscre.org/ns/eReg-
Final/2011/ResponseOCWithSummaryV2_1 ResponseOCWithSummaryV2_1.xsd ">
  <GatewayResponse>
    <TypeCode>0</TypeCode>
    <Acknowledgement>
      <AcknowledgementDetails>
        <UniqueID schemeAgencyName="" schemeName="">UniqueID</UniqueID>
        <ExpectedResponseDateTime>2001-12-31T12:00:00</ExpectedResponseDateTime>
        <MessageDescription xsi:type="TextType">MessageDescription</MessageDescription>
      </AcknowledgementDetails>
    </Acknowledgement>
    <Rejection>
      <ExternalReference>
        <Reference xsi:type="TextType">Reference</Reference>
        <AllocatedBy xsi:type="TextType">AllocatedBy</AllocatedBy>
        <Description xsi:type="TextType">Description</Description>
      </ExternalReference>
      <ActualPrice>
        <GrossPriceAmount currencyID="">0.0</GrossPriceAmount>
        <NetPriceAmount currencyID="">0.0</NetPriceAmount>
        <VATAmount currencyID="">0.0</VATAmount>
      </ActualPrice>
      <RejectionResponse>
        <Reason xsi:type="TextType">Reason</Reason>
        <Code xsi:type="TextType">Code</Code>
        <OtherDescription xsi:type="TextType">OtherDescription</OtherDescription>
        <ValidationErrors>
          <Code xsi:type="TextType">Code</Code>
          <Description xsi:type="TextType">Description</Description>
        </ValidationErrors>
      </RejectionResponse>
    </Rejection>
    <Results>
      <MessageDetails>
        <Description xsi:type="TextType">Description</Description>
      </MessageDetails>
      <ExternalReference>
        <Reference xsi:type="TextType">Reference</Reference>
        <AllocatedBy xsi:type="TextType">AllocatedBy</AllocatedBy>
        <Description xsi:type="TextType">Description</Description>
      </ExternalReference>
      <ActualPrice>
        <GrossPriceAmount currencyID="">0.0</GrossPriceAmount>
        <NetPriceAmount currencyID="">0.0</NetPriceAmount>
        <VATAmount currencyID="">0.0</VATAmount>
      </ActualPrice>
      <Attachment>
        <EmbeddedFileBinaryObject characterSetCode="" filename="" format="" mimeType="">MA=</EmbeddedFileBinaryObject>
        <Title xsi:type="TextType">Title</Title>
        <Description xsi:type="TextType">Description</Description>
        <Date xsi:type="DateType">2001-01-01</Date>
        <CopyrightNotices xsi:type="TextType">CopyrightNotices</CopyrightNotices>
      </Attachment>
      <OCSummaryData>
        <OfficialCopyDateTime>2001-12-31T12:00:00</OfficialCopyDateTime>
        <EditionDate xsi:type="DateType">2001-01-01</EditionDate>
        <PricePaidEntry>
          <MultipleTitleIndicator>2</MultipleTitleIndicator>
          <EntryDetails>
            <EntryNumber xsi:type="TextType">EntryNumber</EntryNumber>
            <EntryText xsi:type="TextType">EntryText</EntryText>
            <RegistrationDate xsi:type="DateType">2001-01-01</RegistrationDate>
            <SubRegisterCode>A</SubRegisterCode>
            <Infills>
              <Amount>Amount</Amount>
            </Infills>
          </EntryDetails>
        </PricePaidEntry>
        <PropertyAddress>
          <PostcodeZone>
            <Postcode xsi:type="TextType">Postcode</Postcode>
          </PostcodeZone>
          <AddressLine>
            <IndexNumeric>0.0</IndexNumeric>
            <Line xsi:type="TextType">Line</Line>
          </AddressLine>
        </PropertyAddress>
        <Title>
          <TitleNumber xsi:type="Q2TextType">TitleNumber</TitleNumber>
          <ClassOfTitleCode>10</ClassOfTitleCode>
          <CommonholdIndicator>true</CommonholdIndicator>
          <TitleRegistrationDetails>
            <DistrictName>DistrictName</DistrictName>
            <AdministrativeArea>AdministrativeArea</AdministrativeArea>
            <LandRegistryOfficeName>LandRegistryOfficeName</LandRegistryOfficeName>
            <LatestEditionDate xsi:type="DateType">2001-01-01</LatestEditionDate>
            <PostcodeZone>
              <Postcode xsi:type="TextType">Postcode</Postcode>
            </PostcodeZone>
            <RegistrationDate xsi:type="DateType">2001-01-01</RegistrationDate>
          </TitleRegistrationDetails>
        </Title>
        <RegisterEntryIndicators>
          <AgreedNoticeIndicator>true</AgreedNoticeIndicator>
          <BankruptcyIndicator>true</BankruptcyIndicator>
          <CautionIndicator>true</CautionIndicator>
          <CCBIIndicator>true</CCBIIndicator>
          <ChargeIndicator>true</ChargeIndicator>
          <ChargeRelatedRestrictionIndicator>true</ChargeRelatedRestrictionIndicator>
          <ChargeRestrictionIndicator>true</ChargeRestrictionIndicator>
          <CreditorsNoticeIndicator>true</CreditorsNoticeIndicator>
        </RegisterEntryIndicators>
      </OCSummaryData>
    </Results>
  </GatewayResponse>
</ResponseOCWithSummaryV2_1>
```

HM Land Registry

Interface Specification



```
<DeathOfProprietorIndicator>true</DeathOfProprietorIndicator>
<DeedOfPostponementIndicator>true</DeedOfPostponementIndicator>
<DiscountChargeIndicator>true</DiscountChargeIndicator>
<EquitableChargeIndicator>true</EquitableChargeIndicator>
<GreenOutEntryIndicator>true</GreenOutEntryIndicator>
<HomeRightsChangeOfAddressIndicator>true</HomeRightsChangeOfAddressIndicator>
<HomeRightsIndicator>true</HomeRightsIndicator>
<LeaseHoldTitleIndicator>true</LeaseHoldTitleIndicator>
<MultipleChargeIndicator>true</MultipleChargeIndicator>
<NonChargeRestrictionIndicator>true</NonChargeRestrictionIndicator>
<NotedChargeIndicator>true</NotedChargeIndicator>
<PricePaidIndicator>true</PricePaidIndicator>
<PropertyDescriptionNotesIndicator>true</PropertyDescriptionNotesIndicator>
<RentChargeIndicator>true</RentChargeIndicator>
<RightOfPreEmptionIndicator>true</RightOfPreEmptionIndicator>
<ScheduleOfLeasesIndicator>true</ScheduleOfLeasesIndicator>
<SubChargeIndicator>true</SubChargeIndicator>
<UnidentifiedEntryIndicator>true</UnidentifiedEntryIndicator>
<UnilateralNoticeBeneficiaryIndicator>true</UnilateralNoticeBeneficiaryIndicator>
<UnilateralNoticeIndicator>true</UnilateralNoticeIndicator>
<VendorsLienIndicator>true</VendorsLienIndicator>
</RegisterEntryIndicators>
<Proprietorship>
  <CurrentProprietorshipDate xsi:type="DateType">2001-01-01</CurrentProprietorshipDate>
  <CautionerParty>
    <PrivateIndividual>
      <Name>
        <ForenamesName xsi:type="TextType">ForenamesName</ForenamesName>
        <SurnameName xsi:type="TextType">SurnameName</SurnameName>
      </Name>
      <Alias>
        <ForenamesName xsi:type="TextType">ForenamesName</ForenamesName>
        <SurnameName xsi:type="TextType">SurnameName</SurnameName>
      </Alias>
    </PrivateIndividual>
    <Address>
      <PostcodeZone>
        <Postcode xsi:type="TextType">Postcode</Postcode>
      </PostcodeZone>
      <AddressLine>
        <IndexNumeric>0.0</IndexNumeric>
        <Line xsi:type="TextType">Line</Line>
      </AddressLine>
    </Address>
    <CharityDetails>
      <CharityName xsi:type="TextType">CharityName</CharityName>
      <CharityAddress>
        <PostcodeZone>
          <Postcode xsi:type="TextType">Postcode</Postcode>
        </PostcodeZone>
        <AddressLine>
          <IndexNumeric>0.0</IndexNumeric>
          <Line xsi:type="TextType">Line</Line>
        </AddressLine>
      </CharityAddress>
      <CharityType>C</CharityType>
    </CharityDetails>
    <TradingName xsi:type="TextType">TradingName</TradingName>
    <PartyNumber xsi:type="TextType">PartyNumber</PartyNumber>
    <PartyDescription xsi:type="TextType">PartyDescription</PartyDescription>
  </CautionerParty>
</Proprietorship>
<Lease>
  <LeaseEntry>
    <LeaseTerm>LeaseTerm</LeaseTerm>
    <LeaseDate xsi:type="TextType">LeaseDate</LeaseDate>
    <Rent>Rent</Rent>
    <LeaseParty>
      <PrivateIndividual>
        <Name>
          <ForenamesName xsi:type="TextType">ForenamesName</ForenamesName>
          <SurnameName xsi:type="TextType">SurnameName</SurnameName>
        </Name>
        <Alias>
          <ForenamesName xsi:type="TextType">ForenamesName</ForenamesName>
          <SurnameName xsi:type="TextType">SurnameName</SurnameName>
        </Alias>
      </PrivateIndividual>
      <Address>
        <PostcodeZone>
          <Postcode xsi:type="TextType">Postcode</Postcode>
        </PostcodeZone>
        <AddressLine>
          <IndexNumeric>0.0</IndexNumeric>
          <Line xsi:type="TextType">Line</Line>
        </AddressLine>
      </Address>
      <CharityDetails>
        <CharityName xsi:type="TextType">CharityName</CharityName>
        <CharityAddress>
          <PostcodeZone>
            <Postcode xsi:type="TextType">Postcode</Postcode>
          </PostcodeZone>
          <AddressLine>
            <IndexNumeric>0.0</IndexNumeric>
            <Line xsi:type="TextType">Line</Line>
          </AddressLine>
        </CharityAddress>
        <CharityType>C</CharityType>
      </CharityDetails>
      <TradingName xsi:type="TextType">TradingName</TradingName>
      <PartyNumber xsi:type="TextType">PartyNumber</PartyNumber>
      <PartyDescription xsi:type="TextType">PartyDescription</PartyDescription>
    </LeaseParty>
  </LeaseEntry>
  <PrivateIndividual>
```

HM Land Registry

Interface Specification



```
<Name>
  <ForenamesName xsi:type="TextType">ForenamesName</ForenamesName>
  <SurnameName xsi:type="TextType">SurnameName</SurnameName>
</Name>
<Alias>
  <ForenamesName xsi:type="TextType">ForenamesName</ForenamesName>
  <SurnameName xsi:type="TextType">SurnameName</SurnameName>
</Alias>
</PrivateIndividual>
<Address>
  <PostcodeZone>
    <Postcode xsi:type="TextType">Postcode</Postcode>
  </PostcodeZone>
  <AddressLine>
    <IndexNumeric>0.0</IndexNumeric>
    <Line xsi:type="TextType">Line</Line>
  </AddressLine>
</Address>
<CharityDetails>
  <CharityName xsi:type="TextType">CharityName</CharityName>
  <CharityAddress>
    <PostcodeZone>
      <Postcode xsi:type="TextType">Postcode</Postcode>
    </PostcodeZone>
    <AddressLine>
      <IndexNumeric>0.0</IndexNumeric>
      <Line xsi:type="TextType">Line</Line>
    </AddressLine>
  </CharityAddress>
  <CharityType>C</CharityType>
</CharityDetails>
<TradingName xsi:type="TextType">TradingName</TradingName>
<PartyNumber xsi:type="TextType">PartyNumber</PartyNumber>
<PartyDescription xsi:type="TextType">PartyDescription</PartyDescription>
</LeaseParty>
<EntryDetails>
  <EntryNumber xsi:type="TextType">EntryNumber</EntryNumber>
  <EntryText xsi:type="TextType">EntryText</EntryText>
  <RegistrationDate xsi:type="DateType">2001-01-01</RegistrationDate>
  <SubRegisterCode>A</SubRegisterCode>
  <Infills>
    <Amount>Amount</Amount>
  </Infills>
</EntryDetails>
</LeaseEntry>
</Lease>
<RestrictionDetails>
  <RestrictionEntry>
    <ChargeRelatedRestriction>
      <RestrictionTypeCode>0</RestrictionTypeCode>
      <ChargeID xsi:type="TextType">ChargeID</ChargeID>
      <EntryDetails>
        <EntryNumber xsi:type="TextType">EntryNumber</EntryNumber>
        <EntryText xsi:type="TextType">EntryText</EntryText>
        <RegistrationDate xsi:type="DateType">2001-01-01</RegistrationDate>
        <SubRegisterCode>A</SubRegisterCode>
        <Infills>
          <Amount>Amount</Amount>
        </Infills>
      </EntryDetails>
    </ChargeRelatedRestriction>
  </RestrictionEntry>
</RestrictionDetails>
<Charge>
  <ChargeEntry>
    <ChargeID xsi:type="TextType">ChargeID</ChargeID>
    <ChargeDate xsi:type="DateType">2001-01-01</ChargeDate>
    <RegisteredCharge>
      <MultipleTitleIndicator xsi:type="TextType">MultipleTitleIndicator</MultipleTitleIndicator>
      <EntryDetails>
        <EntryNumber xsi:type="TextType">EntryNumber</EntryNumber>
        <EntryText xsi:type="TextType">EntryText</EntryText>
        <RegistrationDate xsi:type="DateType">2001-01-01</RegistrationDate>
        <SubRegisterCode>A</SubRegisterCode>
        <Infills>
          <Amount>Amount</Amount>
        </Infills>
      </EntryDetails>
    </RegisteredCharge>
  <ChargeProprietor>
    <ChargeParty>
      <PrivateIndividual>
        <Name>
          <ForenamesName xsi:type="TextType">ForenamesName</ForenamesName>
          <SurnameName xsi:type="TextType">SurnameName</SurnameName>
        </Name>
        <Alias>
          <ForenamesName xsi:type="TextType">ForenamesName</ForenamesName>
          <SurnameName xsi:type="TextType">SurnameName</SurnameName>
        </Alias>
      </PrivateIndividual>
    <Address>
      <PostcodeZone>
        <Postcode xsi:type="TextType">Postcode</Postcode>
      </PostcodeZone>
      <AddressLine>
        <IndexNumeric>0.0</IndexNumeric>
        <Line xsi:type="TextType">Line</Line>
      </AddressLine>
    </Address>
    <CharityDetails>
      <CharityName xsi:type="TextType">CharityName</CharityName>
      <CharityAddress>
        <PostcodeZone>
          <Postcode xsi:type="TextType">Postcode</Postcode>
        </PostcodeZone>
      </CharityAddress>
    </CharityDetails>
  </ChargeParty>
</ChargeProprietor>
</ChargeEntry>
</Charge>
```

HM Land Registry

Interface Specification



```
<AddressLine>
  <IndexNumeric>0.0</IndexNumeric>
  <Line xsi:type="TextType">Line</Line>
</AddressLine>
</CharityAddress>
<CharityType>C</CharityType>
</CharityDetails>
<TradingName xsi:type="TextType">TradingName</TradingName>
<PartyNumber xsi:type="TextType">PartyNumber</PartyNumber>
<PartyDescription xsi:type="TextType">PartyDescription</PartyDescription>
</ChargeeParty>
<EntryDetails>
  <EntryNumber xsi:type="TextType">EntryNumber</EntryNumber>
  <EntryText xsi:type="TextType">EntryText</EntryText>
  <RegistrationDate xsi:type="DateType">2001-01-01</RegistrationDate>
  <SubRegisterCode>A</SubRegisterCode>
  <Infills>
    <Amount>Amount</Amount>
  </Infills>
</EntryDetails>
</ChargeProprietor>
<SubCharge>
  <ChargeDate xsi:type="DateType">2001-01-01</ChargeDate>
  <RegisteredCharge>
    <MultipleTitleIndicator xsi:type="TextType">MultipleTitleIndicator</MultipleTitleIndicator>
    <EntryDetails>
      <EntryNumber xsi:type="TextType">EntryNumber</EntryNumber>
      <EntryText xsi:type="TextType">EntryText</EntryText>
      <RegistrationDate xsi:type="DateType">2001-01-01</RegistrationDate>
      <SubRegisterCode>A</SubRegisterCode>
      <Infills>
        <Amount>Amount</Amount>
      </Infills>
    </EntryDetails>
  </RegisteredCharge>
</ChargeProprietor>
<ChargeParty>
  <PrivateIndividual>
    <Name>
      <ForenamesName xsi:type="TextType">ForenamesName</ForenamesName>
      <SurnameName xsi:type="TextType">SurnameName</SurnameName>
    </Name>
    <Alias>
      <ForenamesName xsi:type="TextType">ForenamesName</ForenamesName>
      <SurnameName xsi:type="TextType">SurnameName</SurnameName>
    </Alias>
  </PrivateIndividual>
  <Address>
    <PostcodeZone>
      <Postcode xsi:type="TextType">Postcode</Postcode>
    </PostcodeZone>
    <AddressLine>
      <IndexNumeric>0.0</IndexNumeric>
      <Line xsi:type="TextType">Line</Line>
    </AddressLine>
  </Address>
  <CharityDetails>
    <CharityName xsi:type="TextType">CharityName</CharityName>
    <CharityAddress>
      <PostcodeZone>
        <Postcode xsi:type="TextType">Postcode</Postcode>
      </PostcodeZone>
      <AddressLine>
        <IndexNumeric>0.0</IndexNumeric>
        <Line xsi:type="TextType">Line</Line>
      </AddressLine>
    </CharityAddress>
    <CharityType>C</CharityType>
  </CharityDetails>
  <TradingName xsi:type="TextType">TradingName</TradingName>
  <PartyNumber xsi:type="TextType">PartyNumber</PartyNumber>
  <PartyDescription xsi:type="TextType">PartyDescription</PartyDescription>
</ChargeeParty>
<EntryDetails>
  <EntryNumber xsi:type="TextType">EntryNumber</EntryNumber>
  <EntryText xsi:type="TextType">EntryText</EntryText>
  <RegistrationDate xsi:type="DateType">2001-01-01</RegistrationDate>
  <SubRegisterCode>A</SubRegisterCode>
  <Infills>
    <Amount>Amount</Amount>
  </Infills>
</EntryDetails>
</ChargeProprietor>
</SubCharge>
</ChargeEntry>
</Charge>
<AgreedNotice>
  <AgreedNoticeEntry>
    <AgreedNoticeType>10</AgreedNoticeType>
    <EntryDetails>
      <EntryNumber xsi:type="TextType">EntryNumber</EntryNumber>
      <EntryText xsi:type="TextType">EntryText</EntryText>
      <RegistrationDate xsi:type="DateType">2001-01-01</RegistrationDate>
      <SubRegisterCode>A</SubRegisterCode>
      <Infills>
        <Amount>Amount</Amount>
      </Infills>
    </EntryDetails>
  </AgreedNoticeEntry>
</AgreedNotice>
<Bankruptcy>
  <EntryDetails>
    <EntryNumber xsi:type="TextType">EntryNumber</EntryNumber>
    <EntryText xsi:type="TextType">EntryText</EntryText>
    <RegistrationDate xsi:type="DateType">2001-01-01</RegistrationDate>
    <SubRegisterCode>A</SubRegisterCode>
```

HM Land Registry

Interface Specification



```
<Infills>
  <Amount>Amount</Amount>
</Infills>
</EntryDetails>
</Bankruptcy>
<Caution>
  <EntryDetails>
    <EntryNumber xsi:type="TextType">EntryNumber</EntryNumber>
    <EntryText xsi:type="TextType">EntryText</EntryText>
    <RegistrationDate xsi:type="DateType">2001-01-01</RegistrationDate>
    <SubRegisterCode>A</SubRegisterCode>
    <Infills>
      <Amount>Amount</Amount>
    </Infills>
  </EntryDetails>
</Caution>
<DeedOfPostponement>
  <EntryDetails>
    <EntryNumber xsi:type="TextType">EntryNumber</EntryNumber>
    <EntryText xsi:type="TextType">EntryText</EntryText>
    <RegistrationDate xsi:type="DateType">2001-01-01</RegistrationDate>
    <SubRegisterCode>A</SubRegisterCode>
    <Infills>
      <Amount>Amount</Amount>
    </Infills>
  </EntryDetails>
</DeedOfPostponement>
<GreenOutEntry>
  <EntryDetails>
    <EntryNumber xsi:type="TextType">EntryNumber</EntryNumber>
    <EntryText xsi:type="TextType">EntryText</EntryText>
    <RegistrationDate xsi:type="DateType">2001-01-01</RegistrationDate>
    <SubRegisterCode>A</SubRegisterCode>
    <Infills>
      <Amount>Amount</Amount>
    </Infills>
  </EntryDetails>
</GreenOutEntry>
<HomeRights>
  <HomeRightsEntry>
    <ChangeOfAddressIndicator>true</ChangeOfAddressIndicator>
    <HomeRightsEntryDetails>
      <EntryNumber xsi:type="TextType">EntryNumber</EntryNumber>
      <EntryText xsi:type="TextType">EntryText</EntryText>
      <RegistrationDate xsi:type="DateType">2001-01-01</RegistrationDate>
      <SubRegisterCode>A</SubRegisterCode>
      <Infills>
        <Amount>Amount</Amount>
      </Infills>
    </HomeRightsEntryDetails>
    <ChangeOfAddressEntryDetails>
      <EntryNumber xsi:type="TextType">EntryNumber</EntryNumber>
      <EntryText xsi:type="TextType">EntryText</EntryText>
      <RegistrationDate xsi:type="DateType">2001-01-01</RegistrationDate>
      <SubRegisterCode>A</SubRegisterCode>
      <Infills>
        <Amount>Amount</Amount>
      </Infills>
    </ChangeOfAddressEntryDetails>
  </HomeRightsEntry>
</HomeRights>
<RentCharge>
  <EntryDetails>
    <EntryNumber xsi:type="TextType">EntryNumber</EntryNumber>
    <EntryText xsi:type="TextType">EntryText</EntryText>
    <RegistrationDate xsi:type="DateType">2001-01-01</RegistrationDate>
    <SubRegisterCode>A</SubRegisterCode>
    <Infills>
      <Amount>Amount</Amount>
    </Infills>
  </EntryDetails>
</RentCharge>
<VendorsLien>
  <EntryDetails>
    <EntryNumber xsi:type="TextType">EntryNumber</EntryNumber>
    <EntryText xsi:type="TextType">EntryText</EntryText>
    <RegistrationDate xsi:type="DateType">2001-01-01</RegistrationDate>
    <SubRegisterCode>A</SubRegisterCode>
    <Infills>
      <Amount>Amount</Amount>
    </Infills>
  </EntryDetails>
</VendorsLien>
<RightOfPreEmption>
  <EntryDetails>
    <EntryNumber xsi:type="TextType">EntryNumber</EntryNumber>
    <EntryText xsi:type="TextType">EntryText</EntryText>
    <RegistrationDate xsi:type="DateType">2001-01-01</RegistrationDate>
    <SubRegisterCode>A</SubRegisterCode>
    <Infills>
      <Amount>Amount</Amount>
    </Infills>
  </EntryDetails>
</RightOfPreEmption>
<DocumentDetails>
  <Document>
    <DocumentType>10</DocumentType>
    <DocumentDate xsi:type="TextType">DocumentDate</DocumentDate>
    <EntryNumber xsi:type="TextType">EntryNumber</EntryNumber>
    <PlanOnlyIndicator>true</PlanOnlyIndicator>
    <FiledUnder xsi:type="TextType">FiledUnder</FiledUnder>
    <RegisterDescription xsi:type="TextType">RegisterDescription</RegisterDescription>
  </Document>
</DocumentDetails>
<UnilateralNoticeDetails>
  <UnilateralNoticeEntry>
```

HM Land Registry

Interface Specification



```
<UnilateralNotice>
  <EntryNumber xsi:type="TextType">EntryNumber</EntryNumber>
  <EntryText xsi:type="TextType">EntryText</EntryText>
  <RegistrationDate xsi:type="DateType">2001-01-01</RegistrationDate>
  <SubRegisterCode>A</SubRegisterCode>
  <Infills>
    <Amount>Amount</Amount>
  </Infills>
</UnilateralNotice>
<UnilateralNoticeBeneficiary>
  <EntryNumber xsi:type="TextType">EntryNumber</EntryNumber>
  <EntryText xsi:type="TextType">EntryText</EntryText>
  <RegistrationDate xsi:type="DateType">2001-01-01</RegistrationDate>
  <SubRegisterCode>A</SubRegisterCode>
  <Infills>
    <Amount>Amount</Amount>
  </Infills>
</UnilateralNoticeBeneficiary>
</UnilateralNoticeEntry>
</UnilateralNoticeDetails>
<DeathOfProprietor>
  <EntryDetails>
    <EntryNumber xsi:type="TextType">EntryNumber</EntryNumber>
    <EntryText xsi:type="TextType">EntryText</EntryText>
    <RegistrationDate xsi:type="DateType">2001-01-01</RegistrationDate>
    <SubRegisterCode>A</SubRegisterCode>
    <Infills>
      <Amount>Amount</Amount>
    </Infills>
  </EntryDetails>
</DeathOfProprietor>
<DiscountCharge>
  <EntryDetails>
    <EntryNumber xsi:type="TextType">EntryNumber</EntryNumber>
    <EntryText xsi:type="TextType">EntryText</EntryText>
    <RegistrationDate xsi:type="DateType">2001-01-01</RegistrationDate>
    <SubRegisterCode>A</SubRegisterCode>
    <Infills>
      <Amount>Amount</Amount>
    </Infills>
  </EntryDetails>
</DiscountCharge>
<EquitableCharge>
  <EntryDetails>
    <EntryNumber xsi:type="TextType">EntryNumber</EntryNumber>
    <EntryText xsi:type="TextType">EntryText</EntryText>
    <RegistrationDate xsi:type="DateType">2001-01-01</RegistrationDate>
    <SubRegisterCode>A</SubRegisterCode>
    <Infills>
      <Amount>Amount</Amount>
    </Infills>
  </EntryDetails>
</EquitableCharge>
<NotedCharge>
  <EntryDetails>
    <EntryNumber xsi:type="TextType">EntryNumber</EntryNumber>
    <EntryText xsi:type="TextType">EntryText</EntryText>
    <RegistrationDate xsi:type="DateType">2001-01-01</RegistrationDate>
    <SubRegisterCode>A</SubRegisterCode>
    <Infills>
      <Amount>Amount</Amount>
    </Infills>
  </EntryDetails>
</NotedCharge>
<CreditorsNotice>
  <EntryDetails>
    <EntryNumber xsi:type="TextType">EntryNumber</EntryNumber>
    <EntryText xsi:type="TextType">EntryText</EntryText>
    <RegistrationDate xsi:type="DateType">2001-01-01</RegistrationDate>
    <SubRegisterCode>A</SubRegisterCode>
    <Infills>
      <Amount>Amount</Amount>
    </Infills>
  </EntryDetails>
</CreditorsNotice>
<UnidentifiedEntry>
  <EntryDetails>
    <EntryNumber xsi:type="TextType">EntryNumber</EntryNumber>
    <EntryText xsi:type="TextType">EntryText</EntryText>
    <RegistrationDate xsi:type="DateType">2001-01-01</RegistrationDate>
    <SubRegisterCode>A</SubRegisterCode>
    <Infills>
      <Amount>Amount</Amount>
    </Infills>
  </EntryDetails>
</UnidentifiedEntry>
<CCBIEntry>
  <EntryDetails>
    <EntryNumber xsi:type="TextType">EntryNumber</EntryNumber>
    <EntryText xsi:type="TextType">EntryText</EntryText>
    <RegistrationDate xsi:type="DateType">2001-01-01</RegistrationDate>
    <SubRegisterCode>A</SubRegisterCode>
    <Infills>
      <Amount>Amount</Amount>
    </Infills>
  </EntryDetails>
</CCBIEntry>
</OCSummaryData>
<OCRegisterData>
  <PropertyRegister>
    <DistrictDetails>
      <EntryText xsi:type="TextType">EntryText</EntryText>
    </DistrictDetails>
    <RegisterEntry>
      <EntryNumber xsi:type="TextType">EntryNumber</EntryNumber>
      <EntryDate xsi:type="TextType">EntryDate</EntryDate>
```

HM Land Registry

Interface Specification



```
<EntryType xsi:type="TextType">EntryType</EntryType>
<EntryText xsi:type="TextType">EntryText</EntryText>
</RegisterEntry>
<Schedule>
  <ScheduleType xsi:type="TextType">ScheduleType</ScheduleType>
  <ScheduleEntry>
    <EntryNumber xsi:type="TextType">EntryNumber</EntryNumber>
    <EntryDate xsi:type="TextType">EntryDate</EntryDate>
    <EntryType xsi:type="TextType">EntryType</EntryType>
    <EntryText xsi:type="TextType">EntryText</EntryText>
  </ScheduleEntry>
</Schedule>
</PropertyRegister>
<ProprietorshipRegister>
  <DistrictDetails>
    <EntryText xsi:type="TextType">EntryText</EntryText>
  </DistrictDetails>
  <RegisterEntry>
    <EntryNumber xsi:type="TextType">EntryNumber</EntryNumber>
    <EntryDate xsi:type="TextType">EntryDate</EntryDate>
    <EntryType xsi:type="TextType">EntryType</EntryType>
    <EntryText xsi:type="TextType">EntryText</EntryText>
  </RegisterEntry>
  <Schedule>
    <ScheduleType xsi:type="TextType">ScheduleType</ScheduleType>
    <ScheduleEntry>
      <EntryNumber xsi:type="TextType">EntryNumber</EntryNumber>
      <EntryDate xsi:type="TextType">EntryDate</EntryDate>
      <EntryType xsi:type="TextType">EntryType</EntryType>
      <EntryText xsi:type="TextType">EntryText</EntryText>
    </ScheduleEntry>
  </Schedule>
</ProprietorshipRegister>
<ChargesRegister>
  <DistrictDetails>
    <EntryText xsi:type="TextType">EntryText</EntryText>
  </DistrictDetails>
  <RegisterEntry>
    <EntryNumber xsi:type="TextType">EntryNumber</EntryNumber>
    <EntryDate xsi:type="TextType">EntryDate</EntryDate>
    <EntryType xsi:type="TextType">EntryType</EntryType>
    <EntryText xsi:type="TextType">EntryText</EntryText>
  </RegisterEntry>
  <Schedule>
    <ScheduleType xsi:type="TextType">ScheduleType</ScheduleType>
    <ScheduleEntry>
      <EntryNumber xsi:type="TextType">EntryNumber</EntryNumber>
      <EntryDate xsi:type="TextType">EntryDate</EntryDate>
      <EntryType xsi:type="TextType">EntryType</EntryType>
      <EntryText xsi:type="TextType">EntryText</EntryText>
    </ScheduleEntry>
  </Schedule>
</ChargesRegister>
</OCRegisterData>
</Results>
</GatewayResponse>
</ResponseOCWithSummaryV2_1>
```